

# Copyright, Warranty and Equipment Return

**Please**—Feel free to duplicate this manual subject to the copyright restrictions below.

## Copyright Notice

The PASCO scientific Model OS-8523 Slit Accessory manual is copyrighted and all rights reserved. However, permission is granted to non-profit educational institutions for reproduction of any part of the Slit Accessory manual providing the reproductions are used only for their laboratories and are not sold for profit. Reproduction under any other circumstances, without the written consent of PASCO scientific, is prohibited.

## Limited Warranty

PASCO scientific warrants the product to be free from defects in materials and workmanship for a period of one year from the date of shipment to the customer. PASCO will repair or replace, at its option, any part of the product which is deemed to be defective in material or workmanship. The warranty does not cover damage to the product caused by abuse or improper use. Determination of whether a product failure is the result of a manufacturing defect or improper use by the customer shall be made solely by PASCO scientific.

Responsibility for the return of equipment for warranty repair belongs to the customer. Equipment must be properly packed to prevent damage and shipped postage or freight prepaid. (Damage caused by improper packing of the equipment for return shipment will not be covered by the warranty.) Shipping costs for returning the equipment after repair will be paid by PASCO scientific.

## Credits

Authors: Ann & Jon Hanks  
Editor: Sunny Bishop



## Equipment Return

Should the product have to be returned to PASCO scientific any reason notify, PASCO scientific by letter or phone BEFORE returning the product. Upon notification, the return authorization and shipping instructions will be promptly issued.

### NOTE:

**NO EQUIPMENT WILL BE ACCEPTED FOR RETURN WITHOUT AN AUTHORIZATION.**

When returning equipment for repair, the units must be packed properly. Carriers will not accept responsibility for damage caused by improper packing. To be certain the unit will not be damaged in shipment, observe the following rules:

- ① The shipping carton must be strong enough for the item shipped.
- ② Make certain there are at least two inches of packing material between any point on the apparatus and the inside walls of the carton.
- ③ Make certain that the packing material can not shift in the box, or become compressed, allowing the instrument come in contact with the edge of the shipping carton.

Address: PASCO scientific  
10101 Foothills Blvd.  
P.O. Box 619011  
Roseville, CA 95678-9011

Phone: (916) 786-3800

FAX: (916) 786-8905

email: techsupp@PASCO.com

# ***Table of Contents***

<b>Section</b>	<b>Page</b>
Copyright, Warranty, and Equipment Return .....	ii
Introduction .....	1
Equipment .....	2
Assembly .....	3
Experiments	
Exp. 1: Diffraction from a Single Slit .....	5
Exp. 2: Interference from a Double Slit .....	9
Exp. 3: Comparisons of Diffraction and Interference Patterns .....	13
Technical Support .....	Inside Back Cover

**Instruction Manual and  
Experiment Guide for  
the PASCO scientific  
Model OS-8523**

012-05880D

# ***SLIT ACCESSORY FOR THE BASIC OPTICS SYSTEM***

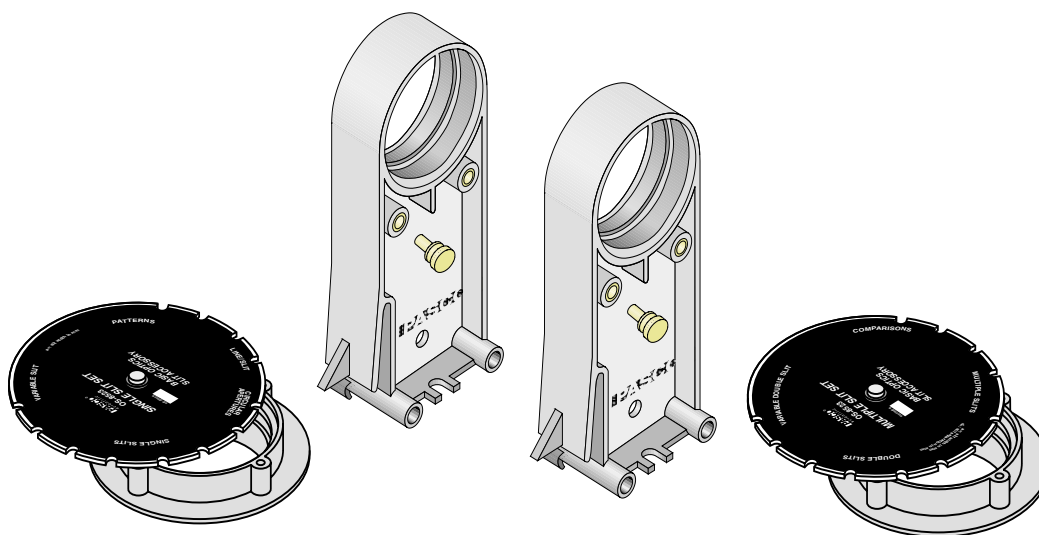

# Introduction

The PASCO OS-8523 Slit Accessory is used with the PASCO OS-8525 Laser Diode on the optics bench in the PASCO OS-8515 Basic Optics System. This set of two disks has many different types of slits for diffraction and interference experiments. The special comparison patterns have two different slits spaced close enough together so they can both be illuminated by a single laser beam at the same time. This allows the student to compare the two different patterns side-by-side so they can see their similarities and differences.

## OS-8523 Slit Accessory specifications:

The contents of the Single Slit Disk are: (See Figure 1)

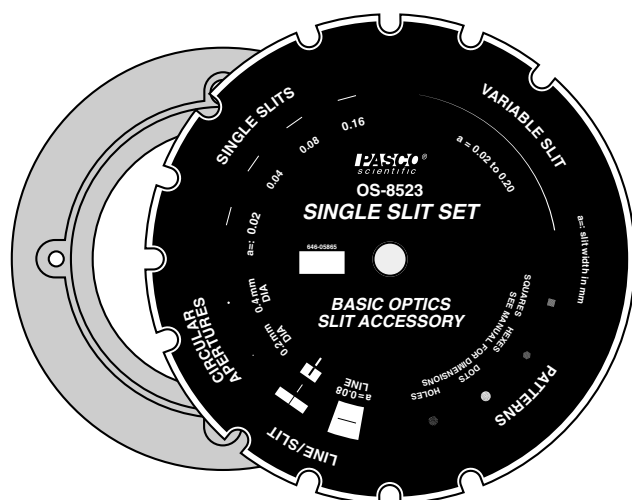

Figure 1: Single Slit Disk

- 4 single slits (slit widths 0.02, 0.04, 0.08, 0.16 mm)
- 1 variable slit (slit width varies from 0.02 to 0.20 mm)
- 1 square pattern
- 1 hexagonal pattern
- 1 random opaque dot pattern (dot diameter = 0.06 mm)
- 1 random hole pattern (hole diameter = 0.06 mm)
- 1 opaque line of width 0.08 mm
- 1 slit/line comparison, line and slit have similar width (0.04 mm)
- 2 circular apertures (diameters 0.2 mm and 0.4 mm)

**NOTE:** Due to limitations of the photographic process used to produce the slit film, the line and slit may not be exactly the same width.

The contents of the Multiple Slit Disk are: (See Figure 2)

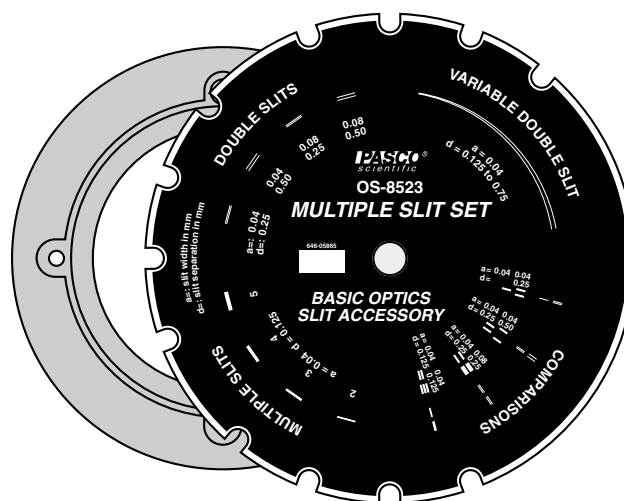
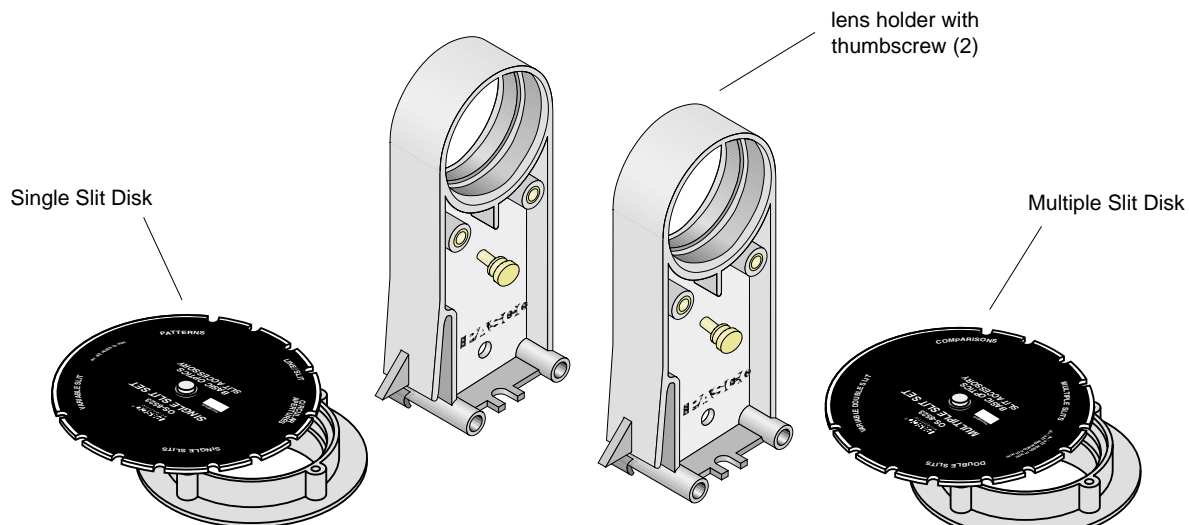

Figure 2: Multiple Slit Disk

- 4 double slits (slit width/separation in mm: 0.04/0.25, 0.04/0.50, 0.08/0.25, 0.08/0.50)
- 1 variable double slit (slit separation varies from 0.125 to 0.75 mm with constant slit width 0.04 mm)
- 4 comparisons: single/double slit with same slit width (0.04 mm)
- double/double slit with same slit width (0.04 mm), different separation (0.25 mm/0.50 mm)
- double/double slit with different slit widths (0.04, 0.08 mm), same separation (0.25 mm)
- double/triple slit with same slit width (0.04 mm), same separation (0.125 mm)
- set of 4 multiple slits (2, 3, 4, 5 slits) with same slit width (0.04 mm), same separation (0.125 mm)

# Equipment



**OS-8523 Slit Accessory Equipment**

**The OS-8523 Slit Accessory includes the following:**

- Single Slit Disk
- Multiple Slit Disk
- lens holder with thumbscrew (2)

# Assembly

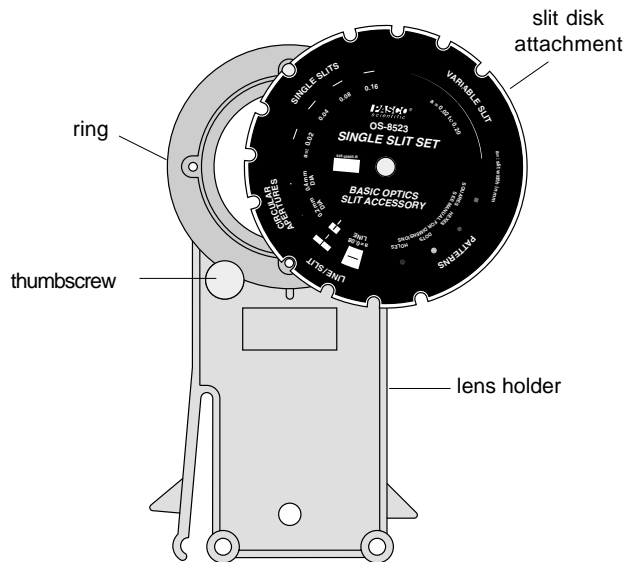

**Figure 3: Slit Accessory and Lens Holder**

## Mounting the Slit Accessory to the Optics Bench

Each of the slit disks is mounted on a ring which snaps into an empty lens holder. The ring should be rotated in the lens holder so the slits at the center of the ring are vertical in the holder. See Figure 3. Tighten the thumb-screw on the holder so the ring cannot rotate during use. To select the desired slits, rotate the disk until it clicks into place with the desired slits at the center of the holder.

**NOTE:** All slits are vertical EXCEPT the comparison slits which are horizontal. The comparison slits are purposely horizontal because the wide laser diode beam will cover both slits to be compared. If you try to rotate these slits to the vertical position, the laser beam may not be large enough to illuminate both slits at the same time.

To align the laser beam and the slits, place the Diode Laser (OS-8525) at one end of the bench. Place the slit holder on the optics bench a few centimeters from the laser with the disk-side of the holder closest to the laser. See Figure 3. Plug in the Diode Laser and turn it on. Adjust the position of the laser beam from left-to-right

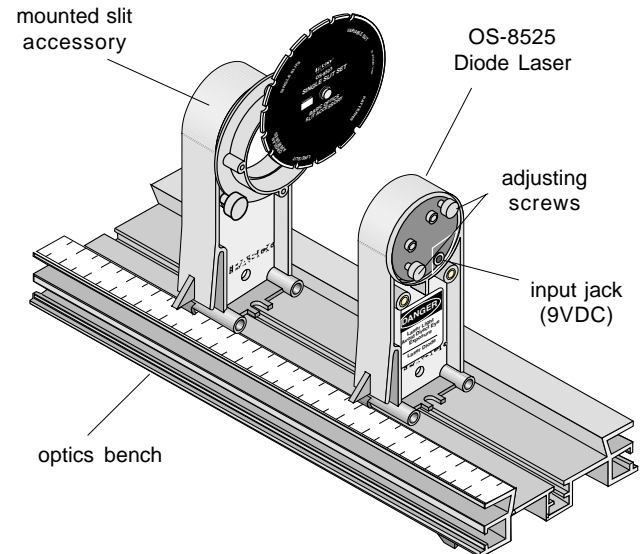

**Figure 4: Using the Slit Accessory with the Diode Laser**

and up-and-down until the beam is centered on the slit. Once this position is set, it is not necessary to make any further adjustments of the laser beam when viewing any of the slits on the disk. When you rotate the disk to a new slit, the laser beam will be already aligned. The slits click into place so you can easily change from one slit to the next, even in the dark.

**Notes:**

# Experiment 1: Diffraction from a Single Slit

## EQUIPMENT REQUIRED

- track and screen from the Basic Optics System (OS-8515)
- Diode Laser (OS-8525)
- Single Slit Disk (OS-8523)
- white paper to cover screen
- metric rule

## Purpose

The purpose of this experiment is to examine the diffraction pattern formed by laser light passing through a single slit and verify that the positions of the minima in the diffraction pattern match the positions predicted by theory.

## Theory

When diffraction of light occurs as it passes through a slit, the angle to the minima in the diffraction pattern is given by

$$a \sin \theta = m\lambda \quad (m = 1, 2, 3, \dots)$$

where  $a$  is the slit width,  $\theta$  is the angle from the center of the pattern to the  $m^{\text{th}}$  minimum,  $\lambda$  is the wavelength of the light, and  $m$  is the order (1 for the first minimum, 2 for the second minimum, . . . counting from the center out). See Figure 1.1.

Since the angles are usually small, it can be assumed that

$$\sin \theta \approx \tan \theta$$

From trigonometry,

$$\tan \theta = \frac{y}{D}$$

where  $y$  is the distance on the screen from the center of the pattern to the  $m^{\text{th}}$  minimum and  $D$  is the distance from the slit to the screen as shown in Figure 1.1. The diffraction equation can thus be solved for the slit width:

$$a = \frac{m\lambda D}{y} \quad (m = 1, 2, 3, \dots)$$

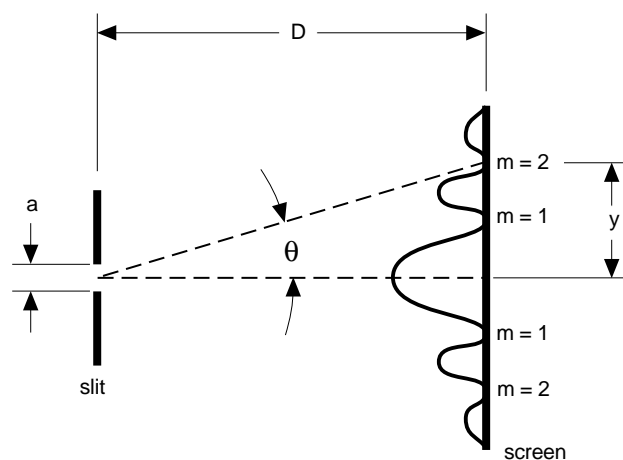

**Figure 1.1: Single Slit Diffraction Pattern**

### Setup

- ① Set up the laser at one end of the optics bench and place the Single Slit Disk in its holder about 3 cm in front of the laser. See Figure 1.2.
- ② Cover the screen with a sheet of paper and attach it to the other end of the bench so that the paper faces the laser.
- ③ Select the 0.04 mm slit by rotating the slit disk until the 0.04 mm slit is centered in the slit holder. Adjust the position of the laser beam from left-to-right and up-and-down until the beam is centered on the slit.

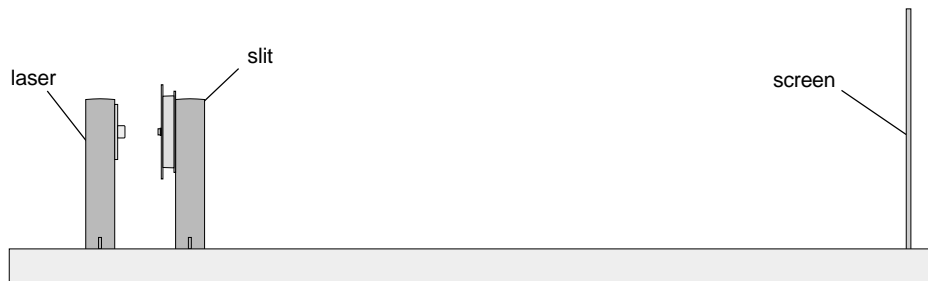

**Figure 1.2: Optics Bench Setup**

### Procedure

- ① Determine the distance from the slit to the screen. Note that the slit is actually offset from the center line of the slit holder. Record the screen position, slit position, and the difference between these (the slit-to-screen distance) in Table 1.1.
- ② Turn off the room lights and mark the positions of the minima in the diffraction pattern on the screen.
- ③ Turn on the room lights and measure the distance between the first order ( $m = 1$ ) marks and record this distance in Table 1.1. Also measure the distance between the second order ( $m = 2$ ) marks and record in Table 1.1.

**Table 1.1: Data and Results for the 0.04 mm Single Slit**

Slit-to-screen distance ( $D$ ) = \_\_\_\_\_

	First Order ( $m=1$ )	Second Order ( $m=2$ )
Distance between side orders		
Distance from center to side ( $y$ )		
Calculated slit width		
% difference		



***Notes:***

## Experiment 2: Interference from a Double Slit

### EQUIPMENT REQUIRED

- track and screen from the Basic Optics System (OS-8515)
- Diode Laser (OS-8525)
- Multiple Slit Disk (OS-8523)
- white paper to cover screen
- metric rule

### Purpose

The purpose of this experiment is to examine the diffraction and interference patterns formed by laser light passing through two slits and verify that the positions of the maxima in the interference pattern match the positions predicted by theory.

### Theory

When light passes through two slits, the two light rays emerging from the slits interfere with each other and produce interference fringes. The angle to the maxima (bright fringes) in the interference pattern is given by

$$d \sin \theta = m\lambda \quad (m = 0, 1, 2, 3, \dots)$$

where  $d$  is the slit separation,  $\theta$  is the angle from the center of the pattern to the  $m^{\text{th}}$  maximum,  $\lambda$  is the wavelength of the light, and  $m$  is the order (0 for the central maximum, 1 for the first side maximum, 2 for the second side maximum, . . . counting from the center out). See Figure 2.1.

Since the angles are usually small, it can be assumed that

$$\sin \theta \approx \tan \theta$$

From trigonometry,

$$\tan \theta = \frac{y}{D}$$

where  $y$  is the distance on the screen from the center of the pattern to the  $m^{\text{th}}$  maximum and  $D$  is the distance from the slits to the screen as shown in Figure 2.1. The interference equation can thus be solved for the slit separation:

$$d = \frac{m\lambda D}{y} \quad (m = 0, 1, 2, 3, \dots)$$

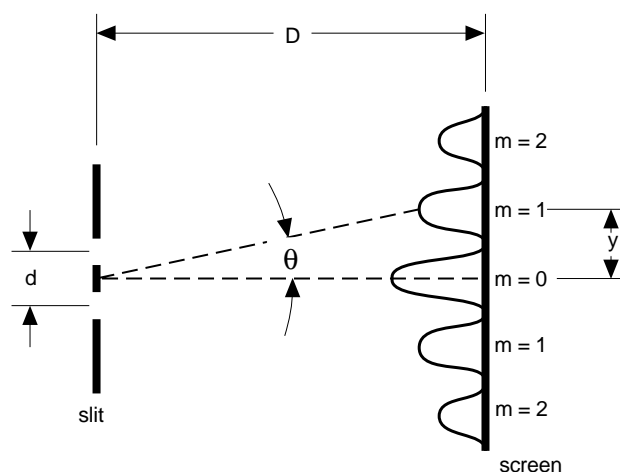

Figure 2.1: Interference Fringes

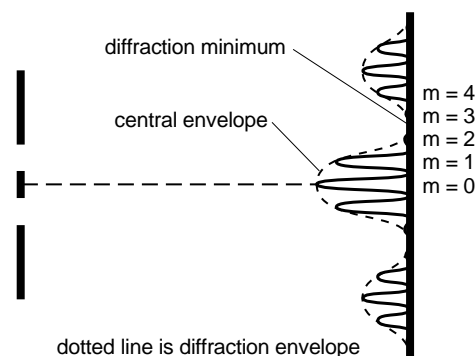
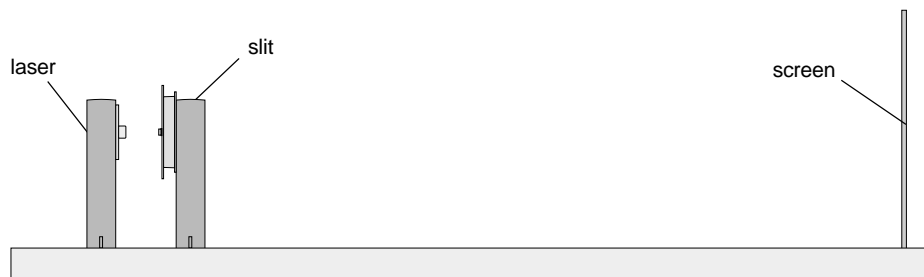

Figure 2.2: Single Slit Diffraction Envelope

While the interference fringes are created by the interference of the light coming from the two slits, there is also a diffraction effect occurring at each slit due to Single Slit diffraction. This causes the envelope as seen in Figure 2.2.

### Setup

- ① Set up the laser at one end of the optics bench and place the Multiple Slit Disk in its holder about 3 cm in front of the laser. See Figure 2.3.



**Figure 2.3: Optics Bench Setup**

- ② Cover the screen with a sheet of paper and attach it to the other end of the bench so that the paper faces the laser.
- ③ Select the double slit with 0.04 mm slit width and 0.25 mm slit separation by rotating the slit disk until the desired double slit is centered in the slit holder. Adjust the position of the laser beam from left-to-right and up-and-down until the beam is centered on the double slit.

### Procedure

- ① Determine the distance from the slits to the screen.  
 Note that the slits are actually offset from the center line of the slit holder. Record the screen position, slit position, and the difference between these (the slit-to-screen distance) in Table 2.1.
- ② Turn off the room lights and mark the positions of the maxima in the interference pattern on the screen.

**Table 2.1: Data and Results for the 0.04 mm/0.25 mm Double Slit**

Slit-to-screen distance (D) = \_\_\_\_\_

	First Order (m=1)	Second Order (m=2)
Distance between side orders		
Distance from center to side (y)		
Calculated slit separation		
% difference		

- ③ Turn on the room lights and measure the distance between the first order ( $m = 1$ ) marks and record this distance in Table 2.1. Also measure the distance between the second order ( $m = 2$ ) marks and record in Table 2.1.
- ④ Make a sketch of the interference pattern to scale.
  
- ⑤ Change to a new double slit with the same slit width (0.04 mm) but different slit separation (0.50 mm) and make a sketch to scale of this new interference pattern.
  
- ⑥ Change to another double slit with a slit width of 0.08 mm and the original slit separation (0.25 mm) and make a sketch to scale of this new interference pattern.

## Analysis

- ① Divide the distances between side orders by two to get the distances from the center of the pattern to the first and second order maxima. Record these values of  $y$  in Table 2.1.
- ② Using the average wavelength of the laser (670 nm for the Diode Laser), calculate the slit separation twice, once using first order and once using second order. Record the results in Table 2.1.
- ③ Calculate the percent differences between the experimental slit separation and 0.25 mm. Record in Table 2.1.

## Questions

- ① Does the distance between maxima increase, decrease, or stay the same when the slit separation is increased?
  
- ② Does the distance between maxima increase, decrease, or stay the same when the slit width is increased?

- ③ Does the distance to the first minima in the diffraction envelope increase, decrease, or stay the same when the slit separation is increased?
- ④ Does the distance to the first minima in the diffraction envelope increase, decrease, or stay the same when the slit width is increased?

## Experiment 3: Comparisons of Diffraction and Interference Patterns

### EQUIPMENT REQUIRED

- track and screen from the Basic Optics System (OS-8515)
- Diode Laser (OS-8525)
- Single and Multiple Slit Disks (OS-8523)
- white paper to cover screen

### Purpose

The purpose of this experiment is to compare the diffraction and interference patterns formed by laser light passing through various combinations of slits.

### Theory

When diffraction of light occurs as it passes through a slit, the angle to the minima in the diffraction pattern is given by

$$a \sin \theta = m\lambda \quad (m = 1, 2, 3, \dots)$$

where  $a$  is the slit width,  $\theta$  is the angle from the center of the pattern to the  $m$ th minimum,  $\lambda$  is the wavelength of the light, and  $m$  is the order (1 for the first minimum, 2 for the second minimum, . . . counting from the center out). See Figure 3.1.

When light passes through two slits, the two light rays emerging from the slits interfere with each other and produce interference fringes. The angle to the maxima (bright fringes) in the interference pattern is given by

$$d \sin \theta = m\lambda \quad (m = 0, 1, 2, 3, \dots)$$

where  $d$  is the slit separation,  $\theta$  is the angle from the center of the pattern to the  $m$ th maximum,  $\lambda$  is the wavelength of the light, and  $m$  is the order (0 for the central maximum, 1 for the first side maximum, 2 for the second side maximum, . . . counting from the center out). See Figure 3.2.

### Setup

- ① Set up the laser at one end of the optics bench and place the Multiple Slit Disk in its holder about 3 cm in front of the laser. See Figure 3.3.

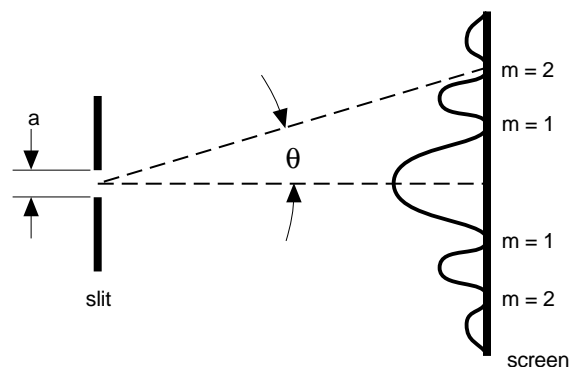

Figure 3.1: Single Slit Diffraction Pattern

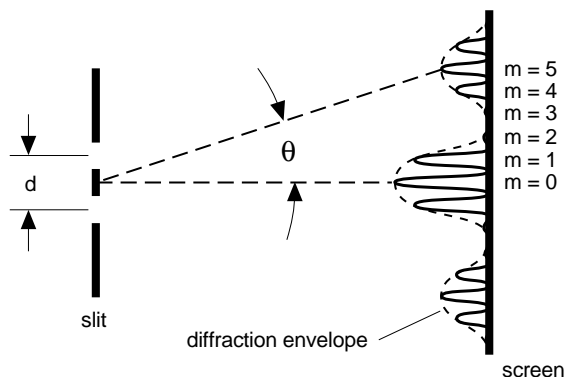
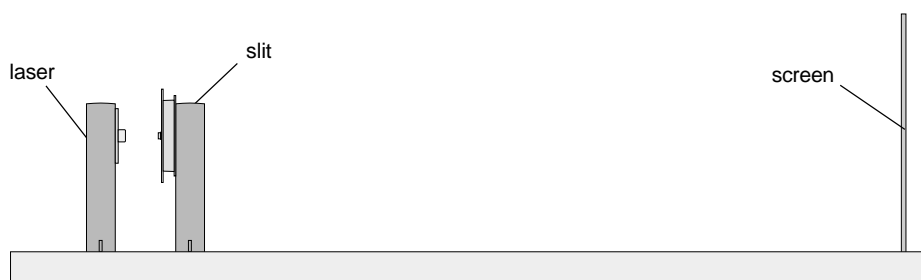

Figure 3.2: Interference Fringes

- ② Cover the screen with a sheet of paper and attach it to the other end of the bench so that the paper faces the laser.



**Figure 3.3: Optics Bench Setup**

- ③ Select the single-double slit comparison by rotating the slit disk until the desired slit set is centered in the slit holder. Adjust the position of the laser beam from left-to-right and up-and-down until the beam is centered on the slit set so that both the single slit and the double slit are illuminated simultaneously. The patterns from the single and double slits should be vertical and side-by-side on the screen.

## Procedure

- ① Sketch the two side-by-side patterns roughly to scale.
- ② Rotate the slit disk to the next comparison set (2 double slits with the same slit width but different slit separations). Sketch the two side-by-side patterns roughly to scale.
- ③ Rotate the slit disk to the next comparison set (2 double slits with the same slit separation but different slit widths). Sketch the two side-by-side patterns roughly to scale.
- ④ Rotate the slit disk to the next comparison set (double slits/triple slits with the same slit separation and same slit widths). Sketch the two side-by-side patterns roughly to scale.

- 
- ⑤ Replace the Multiple Slit Disk with the Single Slit Disk. Select the line/slit comparison. Sketch the two side-by-side patterns roughly to scale.
- ⑥ Select the dot pattern on the Single Slit Disk. Sketch the resulting diffraction pattern roughly to scale.
- ⑦ Select the hole pattern on the Single Slit Disk. Sketch the resulting diffraction pattern roughly to scale.

## Questions

- ① What are the similarities and differences between the single slit and the double slit?
- ② How does the double slit pattern change when the slit separation is increased?
- ③ How does the double slit pattern change when the slit width is increased?
- ④ What differences are there between a double slit pattern and a triple slit pattern?

- ⑤ How does the diffraction pattern from a slit differ from the diffraction pattern from a line?
- ⑥ How does the diffraction pattern from the dot pattern differ from the diffraction pattern from the hole pattern?

# Technical Support

## Feedback

If you have any comments about the product or manual, please let us know. If you have any suggestions on alternate experiments or find a problem in the manual, please tell us. PASCO appreciates any customer feedback. Your input helps us evaluate and improve our product.

## To Reach PASCO

For technical support, call us at 1-800-772-8700 (toll-free within the U.S.) or (916) 786-3800.

fax: (916) 786-3292

e-mail: [techsupp@pasco.com](mailto:techsupp@pasco.com)

web: [www.pasco.com](http://www.pasco.com)

## Contacting Technical Support

Before you call the PASCO Technical Support staff, it would be helpful to prepare the following information:

- ▶ If your problem is with the PASCO apparatus, note:
  - Title and model number (usually listed on the label);
  - Approximate age of apparatus;
  - A detailed description of the problem/sequence of events (in case you can't call PASCO right away, you won't lose valuable data);
  - If possible, have the apparatus within reach when calling to facilitate description of individual parts.
  
- ▶ If your problem relates to the instruction manual, note:
  - Part number and revision (listed by month and year on the front cover);
  - Have the manual at hand to discuss your questions.