The P/Q Mathematics Study Guide

Copyright © 2007 by
Lawrence Perez and Patrick Quigley
All Rights Reserved

Table of Contents

Ch. 1 Numerical Operations

- §1-1 Integers
- §1-2 Fractions
- §1-3 Proportion and Percent

Ch. 2 Variable Expressions

- §2-1 Integer Exponents
- §2-2 Polynomial Expressions
- §2-3 Rational Expressions
- §2-4 Radical Expressions

Ch. 3 Equations

- §3-1 Linear Equations
- §3-2 Quadratic Equations
- §3-3 Absolute Value Equations
- §3-4 Rational Equations
- §3-5 Radical Equations

Ch. 4 Inequalities

- §4-1 Linear Inequalities
- §4-2 Quadratic Inequalities
- §4-3 Absolute Value Inequalities

Ch. 5 Relations and Functions

- §5-1 Coordinate Geometry
- §5-2 Linear Relations
- §5-3 Systems of Relations
- §5-4 Functions

Ch. 6 Geometry

- §6-1 Perimeter and Circumference
- §6-2 Area
- §6-3 Volume
- §6-4 Angles in a Plane
- §6-5 Special Triangles
- §6-6 Trigonometry

Ch. 7 Probability and Statistics

- §7-1 Counting
- §7-2 Probability
- §7-3 Tables and Graphs
- §7-4 Statistics

§1-1**INTEGERS****Definition**

The set of **integers**, Z , consists of the whole numbers and their negative counterparts.

$$Z = \{ \dots, -3, -2, -1, 0, 1, 2, 3, \dots \}$$

Definition

The absolute value of a number is the distance between the number and zero on a number line.

It is defined by the formula: $|x| = \begin{cases} x, & \text{if } x \geq 0 \\ -x, & \text{if } x < 0 \end{cases}$

Example 1

Evaluate each absolute value below.

a. $|5| = 5$

b. $|-5| = 5$

c. $|0| = 0$

Property**Multiplying Integers**

To multiply two integers, first multiply their absolute values. If the integers have the same sign then the result is positive, otherwise the result is negative.

Example 2

Multiply the integers below.

a. $3 \cdot 2 = 6$

b. $3 \cdot (-2) = -6$

c. $(-3) \cdot 2 = -6$

d. $(-3) \cdot (-2) = 6$

Property**Dividing Integers**

To divide two integers, first divide their absolute values. If the integers have the same sign then the result is positive, otherwise the result is negative.

Example 3

Divide the integers below.

a. $10 \div 2 = 5$

b. $10 \div (-2) = -5$

c. $(-10) \div 2 = -5$

d. $(-10) \div (-2) = 5$

Property**Adding Integers**

To add two integers which have the same sign, add their absolute values and give the result the same sign as the integers.

To add two integers with opposite signs, subtract the smaller absolute value from the larger and give the result the sign of the integer with the larger absolute value.

Example 4

Add the integers below.

a. $3 + 5 = 8$

b. $3 + (-5) = -2$

c. $(-3) + 5 = 2$

d. $(-3) + (-5) = -8$

Property**Subtracting Integers**

To subtract two integers change the subtraction symbol to addition while reversing the sign of the second integer. Then use the rules for addition.

Example 5

Subtract the integers below.

a. $3 - 5 = 3 + (-5) = -2$

b. $3 - (-5) = 3 + 5 = 8$

c. $(-3) - 5 = (-3) + (-5) = -8$

d. $(-3) - (-5) = (-3) + 5 = 2$

Evaluate each absolute value.

1. $|7|$ 2. $|-3|$ 3. $|0|$ 4. $|-75|$
5. $|-16|$ 6. $|15|$ 7. $|-7|$ 8. $|1|$

Multiply the integers.

9. $7 \cdot 12$ 10. $(-9) \cdot 3$ 11. $3 \cdot (-16)$ 12. $(-10) \cdot (-5)$
13. $(-5) \cdot 4$ 14. $(-6) \cdot (-11)$ 15. $11 \cdot 8$ 16. $3 \cdot (-8)$
17. $6 \cdot (-7)$ 18. $(-12) \cdot 9$ 19. $(-2) \cdot (-13)$ 20. $6 \cdot 9$

Divide the integers.

21. $(-20) \div (-4)$ 22. $12 \div 3$ 23. $36 \div (-9)$ 24. $(-9) \div 3$
25. $(-80) \div 20$ 26. $(-15) \div (-3)$ 27. $64 \div 4$ 28. $13 \div (-1)$
29. $42 \div (-7)$ 30. $108 \div 12$ 31. $(-72) \div 8$ 32. $(-121) \div (-11)$

Add the integers.

33. $(-3) + 5$ 34. $13 + (-6)$ 35. $(-15) + (-8)$ 36. $5 + 7$
37. $(-2) + (-5)$ 38. $9 + 12$ 39. $(-11) + 4$ 40. $4 + (-8)$
41. $1 + (-7)$ 42. $(-16) + (-3)$ 43. $18 + 6$ 44. $(-3) + 6$

Subtract the integers.

45. $(-3) - 5$ 46. $13 - (-6)$ 47. $(-15) - (-8)$ 48. $5 - 7$
49. $(-2) - (-5)$ 50. $9 - 12$ 51. $(-11) - 4$ 52. $4 - (-8)$
53. $1 - (-7)$ 54. $(-16) - (-3)$ 55. $18 - 6$ 56. $(-3) - 6$

Evaluate.

57. $(11 - 19)(3 - 8)$ 58. $(3 - 7)(8 - 5)$ 59. $5(-3) - 11$
60. $31 - (-1)(-2)$ 61. $(12 - 15)(-3)$ 62. $(4)(17 - 19)$
63. $14 - 7 - 22$ 64. $8 - 9 - 11$ 65. $6 - (-12 + 5)$
66. $8 - (11 - 17)$ 67. $18 + (12 \div 3)$ 68. $7 - (80 \div 16)$
69. $(-4)(5) \div (-2)$ 70. $(-15)(2) \div (6)$ 71. $(20 - 4) \div (17 - 21)$
72. $|15 + (-12)|$ 73. $|(-7) \cdot 4|$ 74. $|7 - 31|$
75. $|(-10) - 12|$ 76. $|(-9) + (-7)|$ 77. $|(-24) \div (-4)|$

- | | | | | |
|----------------|----------------|-----------------|----------------|----------------|
| 1. 7 | 2. 3 | 3. 0 | 4. 75 | 5. 16 |
| 6. 15 | 7. 7 | 8. 1 | 9. 84 | 10. -27 |
| 11. -48 | 12. 50 | 13. -20 | 14. 66 | 15. 88 |
| 16. -24 | 17. -42 | 18. -108 | 19. 26 | 20. 54 |
| 21. 5 | 22. 4 | 23. -4 | 24. -3 | 25. -4 |
| 26. 5 | 27. 16 | 28. -13 | 29. -6 | 30. 9 |
| 31. -9 | 32. 11 | 33. 2 | 34. 7 | 35. -23 |
| 36. 12 | 37. -7 | 38. 21 | 39. -7 | 40. -4 |
| 41. -6 | 42. -19 | 43. 24 | 44. 3 | 45. -8 |
| 46. 19 | 47. -7 | 48. -2 | 49. 3 | 50. -3 |
| 51. -15 | 52. 12 | 53. 8 | 54. -13 | 55. 12 |
| 56. -9 | 57. 40 | 58. -12 | 59. -26 | 60. 29 |
| 61. 9 | 62. -8 | 63. -15 | 64. -12 | 65. 13 |
| 66. 14 | 67. 22 | 68. 2 | 69. 10 | 70. -5 |
| 71. -4 | 72. 3 | 73. 28 | 74. 24 | 75. 22 |
| 76. 16 | 77. 6 | | | |

§1-2**FRACTIONS****Properties**

If $\frac{p}{q}$ is a fraction and if $r \neq 0$ then $\frac{p}{q} = \frac{p \div r}{q \div r}$ and $\frac{p}{q} = \frac{p \cdot r}{q \cdot r}$.

Example 1

Reduce the fractions below.

$$\text{a. } \frac{13}{39} = \frac{13 \div 13}{39 \div 13} = \frac{1}{3} \quad \text{b. } \frac{6}{50} = \frac{6 \div 2}{50 \div 2} = \frac{3}{25} \quad \text{c. } -\frac{14}{49} = -\frac{14 \div 7}{49 \div 7} = -\frac{2}{7}$$

Procedure**Multiplying Fractions**

The product of the fractions $\frac{p}{q}$ and $\frac{r}{s}$ is $\frac{p}{q} \cdot \frac{r}{s} = \frac{pr}{qs}$.

Example 2

Multiply the fractions below. Reduce your answers.

$$\text{a. } -\frac{1}{5} \cdot \frac{2}{3} = -\frac{1 \cdot 2}{5 \cdot 3} = -\frac{2}{15} \quad \text{b. } \frac{1}{4} \cdot \frac{2}{3} = \frac{1 \cdot 2}{4 \cdot 3} = \frac{2}{12} = \frac{2 \div 2}{12 \div 2} = \frac{1}{6}$$

Procedure**Dividing Fractions**

The quotient of the fractions $\frac{p}{q}$ and $\frac{r}{s}$ is $\frac{p}{q} \div \frac{r}{s} = \frac{p}{q} \cdot \frac{s}{r} = \frac{ps}{qr}$.

Example 3

Divide the fractions below. Reduce your answers.

$$\text{a. } -\frac{1}{5} \div \frac{2}{3} = -\frac{1}{5} \cdot \frac{3}{2} = -\frac{1 \cdot 3}{5 \cdot 2} = -\frac{3}{10} \quad \text{b. } \frac{1}{4} \div \frac{3}{8} = \frac{1}{4} \cdot \frac{8}{3} = \frac{1 \cdot 8}{4 \cdot 3} = \frac{8}{12} = \frac{8 \div 4}{12 \div 4} = \frac{2}{3}$$

Procedure**Adding Fractions**

The sum of the fractions $\frac{p}{q}$ and $\frac{r}{s}$ is $\frac{p}{q} + \frac{r}{q} = \frac{p+r}{q}$.

Example 4

Add the fractions below. Reduce your answers.

$$\frac{3}{20} + \frac{1}{4} = \frac{3}{20} + \frac{1 \cdot 5}{4 \cdot 5} = \frac{3}{20} + \frac{5}{20} = \frac{3+5}{20} = \frac{8}{20} = \frac{8 \div 4}{20 \div 4} = \frac{2}{5}$$

Procedure**Subtracting Fractions**

The difference of the fractions $\frac{p}{q}$ and $\frac{r}{q}$ is $\frac{p}{q} - \frac{r}{q} = \frac{p-r}{q}$.

Example 5

Subtract the fractions below. Reduce your answers.

$$\frac{8}{35} + \frac{1}{5} = \frac{8}{35} + \frac{1 \cdot 7}{5 \cdot 7} = \frac{8}{35} + \frac{7}{35} = \frac{8+7}{35} = \frac{15}{35} = \frac{15 \div 5}{35 \div 5} = \frac{3}{7}$$

Reduce each fraction.

1. $\frac{3}{12}$ 2. $\frac{7}{-35}$ 3. $\frac{13}{52}$ 4. $-\frac{11}{121}$ 5. $\frac{25}{45}$
 6. $\frac{8}{12}$ 7. $\frac{-42}{72}$ 8. $\frac{300}{6}$ 9. $\frac{-85}{-68}$ 10. $\frac{156}{130}$

Multiply. Reduce when possible.

11. $\frac{1}{2} \cdot \frac{3}{4}$ 12. $\left(-\frac{2}{3}\right) \cdot \frac{3}{7}$ 13. $\frac{5}{7} \cdot \frac{14}{15}$ 14. $\frac{23}{50} \cdot \left(-\frac{5}{7}\right)$
 15. $\frac{7}{27} \cdot \frac{9}{14}$ 16. $2\frac{1}{3} \cdot 3\frac{1}{4}$ 17. $\frac{4}{15} \cdot \frac{6}{16}$ 18. $\left(-\frac{12}{25}\right)\left(-\frac{13}{44}\right)$

Divide. Reduce when possible.

19. $\frac{1}{4} \div \frac{1}{2}$ 20. $\frac{5}{42} \div \frac{2}{7}$ 21. $\frac{2}{3} \div \left(-\frac{1}{6}\right)$ 22. $\left(-\frac{1}{3}\right) \div \left(-\frac{1}{6}\right)$
 23. $\left(-\frac{3}{10}\right) \div \frac{3}{5}$ 24. $\frac{5}{24} \div \frac{7}{18}$ 25. $\frac{12}{11} \div \frac{60}{17}$ 26. $3\frac{1}{2} \div 1\frac{1}{4}$

Add or subtract. Reduce when possible.

27. $\frac{1}{2} + \frac{1}{4}$ 28. $\left(-\frac{1}{3}\right) + \frac{3}{7}$ 29. $\frac{2}{5} + \frac{4}{15}$ 30. $\left(-\frac{1}{2}\right) + \left(-\frac{1}{3}\right)$
 31. $\frac{6}{35} + \frac{3}{7}$ 32. $\frac{1}{10} + \frac{2}{5}$ 33. $\frac{2}{5} + \left(-\frac{1}{3}\right)$ 34. $2\frac{1}{6} + 5\frac{1}{3}$
 35. $\frac{1}{2} - \frac{1}{4}$ 36. $\frac{1}{2} - \frac{1}{3}$ 37. $\frac{5}{7} - \frac{1}{2}$ 38. $\left(-\frac{4}{15}\right) - \left(-\frac{1}{5}\right)$
 39. $\frac{2}{7} - \frac{7}{30}$ 40. $\frac{1}{3} - \left(-\frac{1}{6}\right)$ 41. $3\frac{1}{3} - 7\frac{1}{5}$ 42. $\left(-\frac{5}{6}\right) - \frac{2}{3}$

Perform the indicated operations. Reduce when possible.

43. $\frac{1}{3}\left(\frac{3}{5} + \frac{3}{4}\right) + \frac{1}{2}$ 44. $\frac{11}{32} - \frac{3}{4} \cdot \frac{1}{4} + \frac{1}{2}$ 45. $\frac{1}{2} + \frac{1}{5} \div \frac{2}{3} + \left(-\frac{1}{3}\right)$
 46. $\left(-\frac{2}{3} - \frac{1}{5}\right) \div \frac{4}{5}$ 47. $\left(-\frac{7}{8}\right) \div \frac{3}{4} + \frac{1}{2}$ 48. $\left(-\frac{2}{3}\right) \cdot \frac{1}{4} \cdot \frac{5}{6} \div \frac{8}{9}$
 49. $\frac{2}{5} \div \frac{1}{3} \cdot \frac{5}{8} \div \frac{5}{6}$ 50. $\frac{2}{3}\left(\frac{1}{4} - \left(\frac{2}{5} - \frac{1}{10}\right)\right)$ 51. $\frac{1}{12} \div \left(-\frac{2}{3}\right) + \left(-\frac{1}{2}\right)$

- | | | | | | | | | | |
|-----|-------------------|-----|-----------------|-----|------------------|-----|------------------|-----|-----------------|
| 1. | $\frac{1}{4}$ | 2. | $-\frac{1}{5}$ | 3. | $\frac{1}{4}$ | 4. | $-\frac{1}{11}$ | 5. | $\frac{5}{9}$ |
| 6. | $\frac{2}{3}$ | 7. | $-\frac{7}{12}$ | 8. | 50 | 9. | $1\frac{1}{4}$ | 10. | $1\frac{1}{5}$ |
| 11. | $\frac{3}{8}$ | 12. | $-\frac{2}{7}$ | 13. | $\frac{2}{3}$ | 14. | $-\frac{23}{70}$ | 15. | $\frac{1}{6}$ |
| 16. | $7\frac{7}{12}$ | 17. | $\frac{1}{10}$ | 18. | $\frac{39}{275}$ | 19. | $\frac{1}{2}$ | 20. | $\frac{5}{12}$ |
| 21. | -4 | 22. | 2 | 23. | $-\frac{1}{2}$ | 24. | $\frac{15}{28}$ | 25. | $\frac{17}{55}$ |
| 26. | $2\frac{4}{5}$ | 27. | $\frac{3}{4}$ | 28. | $\frac{2}{21}$ | 29. | $\frac{2}{3}$ | 30. | $-\frac{5}{6}$ |
| 31. | $\frac{3}{5}$ | 32. | $\frac{1}{2}$ | 33. | $\frac{1}{15}$ | 34. | $7\frac{1}{2}$ | 35. | $\frac{1}{4}$ |
| 36. | $\frac{1}{6}$ | 37. | $\frac{3}{14}$ | 38. | $-\frac{1}{15}$ | 39. | $\frac{11}{210}$ | 40. | $\frac{1}{2}$ |
| 41. | $-3\frac{13}{15}$ | 42. | $-1\frac{1}{2}$ | 43. | $\frac{19}{20}$ | 44. | $\frac{21}{32}$ | 45. | $\frac{7}{15}$ |
| 46. | $-1\frac{1}{12}$ | 47. | $-\frac{2}{3}$ | 48. | $-\frac{5}{32}$ | 49. | $\frac{9}{10}$ | 50. | $-\frac{1}{30}$ |
| 51. | $-\frac{5}{8}$ | | | | | | | | |

§1-3**PROPORTION AND PERCENT****Definition**

A **ratio** is an ordered pair of numbers written $\frac{x}{y}$ where $y \neq 0$.

Theorem**Equality of Ratios**

$\frac{a}{b} = \frac{c}{d}$ if and only if $ad = bc$, where a, b, c and d are real numbers and $b \neq 0, d \neq 0$.

Definition

A **proportion** is a statement that two ratios are equal.

Example 1

Sam uses three tablespoons of instant cocoa to make two servings of hot cocoa. How many tablespoons of instant cocoa does Sam need if he is to make five servings of hot cocoa?

Solution

Sam uses a ratio of 3 tablespoons of mix to 2 servings of hot water. Since Sam needs the same ratio of tablespoons of mix to 5 servings of hot water we get the following proportion.

$$\frac{3}{2} = \frac{x}{5}$$

where x is the number of tablespoons of mix required. Solving this equation for x :

$$2x = 15$$

$$x = \frac{15}{2}$$

$$x = 7\frac{1}{2} \text{ tablespoons}$$

Definition

Percent means parts per hundred. Thus $n\%$ represents the ratio $\frac{n}{100}$.

Example 2

What is 30% of 150?

Solution

$$(30\%)(150) = (0.30)(150) = 45$$

Example 3

15 is what percentage of 180?

Solution

$$15 \div 180 = 0.08\bar{3} = 8.\bar{3}\% = 8\frac{1}{3}\%$$

Example 4

Suppose apples cost \$1.15 per pound. If oranges cost 20% more than apples, how much will three pounds of oranges cost?

Solution

$$\text{We first calculate 20\% of \$1.15: } (20\%)(\$1.15) = (0.2)(\$1.15) = \$0.23.$$

Therefore each pound of oranges cost 23 cents more than each pound of apples.

This implies that the cost of 1 pound of oranges is $\$1.15 + .23 = \1.38 .

We conclude 3 pounds of oranges costs, $3(\$1.38) = \4.14 .

Find the ratio of each pair of quantities.

1. 8 feet to 4 inches
2. $2\frac{1}{2}$ gallons to 3 quarts
3. 40 seconds to $\frac{1}{3}$ minute
4. \$1.65 to 5¢
5. 1 hour and 15 minutes to 5 hours

In each of the following proportions, find the value of x .

6. $\frac{3}{5} = \frac{15}{x}$
7. $\frac{x}{49} = \frac{9}{21}$
8. $\frac{3}{x} = \frac{2}{15}$
9. $\frac{1.5}{4} = \frac{8.4}{x}$
10. $\frac{1}{27} = \frac{x}{3}$
11. $\frac{2x}{5} = \frac{4}{3}$
12. $\frac{9}{2} = \frac{3x}{14}$
13. $\frac{33}{x} = \frac{11}{5}$
14. $\frac{2}{x} = \frac{b}{3}$
15. $\frac{9}{x} = \frac{x}{16}$
16. $\frac{r}{s} = \frac{c}{x}$
17. $\frac{b}{x} = \frac{3}{b^2}$

Solve each proportion problem.

18. Candy bars sell at a rate of 3 for 42¢. What will 10 candy bars cost?
19. A wheelbarrow can carry 53 lbs in 7 loads. How many trips are needed to haul 140 lbs?
20. If three painters could paint four apartments in a day, then how many apartments could five painters paint in a day?
21. 55 miles per hour is approximately 88 kilometers per hour. If a car travels at 90 miles per hour, then approximately how many kilometers per hour is it traveling?
22. The scale on a map is $\frac{3}{4}$ inches to 6 miles. How far apart are two cities if the map shows them as 4 inches apart?

Solve each percentage problem.

23. What is 12% of 1300?
24. 238 is what percentage of 1400?
25. A jacket regularly costs \$104.20. If it is on sale at 20% off then how much does it cost?
26. If a realtor earns a 5% commission on every house that she sells, then how much will she earn on the sale of a \$123,000 house?
27. At Albert Einstein Junior High School there are 123 students who participate in sports. If this represents 15% of the student body, then how many students attend Albert Einstein JHS?

§1-3**PROBLEM SOLUTIONS**

1. $\frac{24}{1}$ 2. $\frac{10}{3}$ 3. $\frac{2}{1}$ 4. $\frac{33}{1}$ 5. $\frac{1}{4}$
6. 25 7. 21 8. $22\frac{1}{2}$ 9. 22.4 10. $\frac{1}{9}$
11. $3\frac{1}{3}$ 12. 21 13. 15 14. $\frac{6}{b}$ 15. ± 12
16. $\frac{cs}{r}$ 17. $\frac{b^3}{3}$ 18. \$1.40 19. 19 trips 20. $6\frac{2}{3}$
21. 144 kph 22. 32 miles 23. 156 24. 17% 25. \$83.36
26. \$6150 27. 820 students

§2-1**INTEGER EXPONENTS****Definition**

a raised to the n th **power**, written as a^n , means a multiplied times itself n times,
 $a^n = \underbrace{a \cdot a \cdot a \cdots a}_{n \text{ factors of } a}$, where a is called the **base** and n is called the **exponent**.

The expression 3^4 is read “3 to the fourth power” and means $3 \times 3 \times 3 \times 3 = 81$.

Properties**Properties of Exponents**

$$a^m a^n = a^{m+n}$$

$$\frac{a^m}{a^n} = a^{m-n}$$

$$(a^m)^n = a^{mn}$$

$$\left(\frac{a}{b}\right)^m = \frac{a^m}{b^m}$$

$$a^{-m} = \frac{1}{a^m}$$

$$\left(\frac{a}{b}\right)^{-m} = \frac{b^m}{a^m}$$

$$a^0 = 1, \text{ where } a \neq 0$$

Examples

$$x^3 x^2 = x^5$$

$$\frac{x^7}{x^4} = x^3$$

$$(x^3)^2 = x^6$$

$$\left(\frac{2x}{y}\right)^2 = \frac{4x^2}{y^2}$$

$$x^{-3} = \frac{1}{x^3}$$

$$\left(\frac{2x}{y}\right)^{-2} = \frac{y^2}{4x^2}$$

$$(-2x^3)^0 = 1, \text{ where } x \neq 0$$

Example 1 Simplify the expression $(2x^2y^{-3})^{-2}$.

Solution

$$\begin{aligned} (2x^2y^{-3})^{-2} &= \frac{1}{(2x^2y^{-3})^2} \\ &= \frac{1}{2^2(x^2)^2(y^{-3})^2} \\ &= \frac{1}{4x^4y^{-6}} \\ &= \frac{y^6}{4x^4} \end{aligned}$$

Example 2 Simplify the expression $\left(\frac{x^3y^{-2}}{x^{-2}y^{-1}}\right)^{-1}$.

Solution

$$\begin{aligned} \left(\frac{x^3y^{-2}}{x^{-2}y^{-1}}\right)^{-1} &= \frac{x^{-3}y^2}{x^2y^1} \\ &= \frac{y^2}{x^3x^2y} \\ &= \frac{y}{x^5} \end{aligned}$$

Example 3 Simplify the expression $x^{-2} \div xy^{-3}$.

Solution

$$\begin{aligned}x^{-2} \div xy^{-3} &= \frac{1}{x^2} \div \frac{x}{y^3} \\ &= \frac{1}{x^2} \cdot \frac{y^3}{x} \\ &= \frac{y^3}{x^3}\end{aligned}$$

Example 4 Simplify the expression $\frac{2x^{-3}y^2z^{-1}}{(xy^3z^{-2})^{-1}}$.

Solution

$$\begin{aligned}\frac{2x^{-3}y^2z^{-1}}{(xy^3z^{-2})^{-1}} &= \frac{2x^{-3}y^2z^{-1}}{x^{-1}y^{-3}z^2} \\ &= \frac{2xy^2y^3}{x^3z^2z} \\ &= \frac{2xy^5}{x^3z^3}\end{aligned}$$

Definition

A number is in **scientific notation** when it is written in the form $a \times 10^n$ where $1 \leq a < 10$ and n is an integer.

Example 5 Convert 12,000 to scientific notation.

Solution

$$\begin{aligned}12,000 &= 1.2 \times 10,000 \\ &= 1.2 \times 10^4\end{aligned}$$

Example 6 Convert -0.0015 to scientific notation.

Solution

$$\begin{aligned}-0.0015 &= -1.5 \div 1000 \\ &= -1.5 \div 10^3 \\ &= -1.5 \times 10^{-3}\end{aligned}$$

Example 7 Convert 6.35×10^4 to decimal notation.

Solution

$$\begin{aligned}6.35 \times 10^4 &= 6.35 \times 10,000 \\ &= 63,500\end{aligned}$$

Example 8 Convert 8.41×10^{-5} to decimal notation.

Solution

$$\begin{aligned}8.41 \times 10^{-5} &= 8.41 \div 10^5 \\ &= 8.41 \div 100,000 \\ &= 0.0000841\end{aligned}$$

Example 9 Multiply $(2.5 \times 10^{-5})(4.0 \times 10^8)$ and express your answer in scientific notation.

Solution

$$\begin{aligned}(2.5 \times 10^{-5})(4.0 \times 10^8) &= (2.5 \cdot 4.0)(10^{-5} \cdot 10^8) \\ &= 10 \times 10^3 \\ &= 1.0 \times 10^4\end{aligned}$$

Simplify each expression.

- | | | | | | | | |
|-----|--|-----|--|-----|--|-----|--|
| 1. | $(a^2b)(ab^4)$ | 2. | $(-3x^2y)^3$ | 3. | $[(2x)^3]^2$ | 4. | $(2rs^4)(r^2s)^4$ |
| 5. | $x^{2n} \cdot x^n$ | 6. | $(r^3s^{-1})^{-2}$ | 7. | $a^{-5} \cdot a^3$ | 8. | $\frac{x^{-3}y^4}{x^4y^9}$ |
| 9. | $\frac{(2a^{-1}b^2)^2}{(a^{-2}b)^3}$ | 10. | $\left(\frac{x^2y^{-3}}{x^{-1}y^{-2}}\right)^{-2}$ | 11. | $(-2xy^{-2})^3$ | 12. | $(-2xy^{-2})^2$ |
| 13. | $\frac{(3x^{-1}y^2z^{-2})^{-2}}{2x^2z^{-2}}$ | 14. | $[(2a^{-1}b^2)^{-2}]^{-1}$ | 15. | $\frac{4a^{-2}b^3c^{-1}}{(ab^2c^{-2})^{-2}}$ | 16. | $\frac{(2a^2c^{-2})^{-3}}{(a^2c^{-1})^{-2}}$ |
| 17. | $\frac{a^{-3}}{a^{-4}}$ | 18. | $\frac{(c^{-2})^{-3}}{(c^{-1})^{-2}}$ | 19. | $\frac{(x-y)^{-3}}{(x-y)^2}$ | 20. | $4x^{-2} + y - (2^{-1}x)^{-2}$ |
| 21. | $\frac{(a+b)^{-3}}{(a+b)^{-2}}$ | 22. | $\left(a + \frac{1}{b} - b^{-1}\right)^2$ | 23. | $\frac{(2^x)^y}{(2^y)^x}$ | 24. | $\frac{(2x)^0}{(a+b)^{-1}}, x \neq 0$ |
| 25. | $\frac{[(-2)^{-1}]^3}{(2^3)^{-1}}$ | 26. | $x(x^{-1} + x)$ | 27. | $(x^{-1} - y^{-1})^{-1}$ | 28. | $\frac{(a+b^0)^{-6}}{(a+1)^{-5}}, b \neq 0$ |

Express each quantity in scientific notation.

- | | | | | | |
|-----|----------|-----|---------------|-----|-----------|
| 29. | 3500 | 30. | 0.004 | 31. | 4,612,000 |
| 32. | 0.000056 | 33. | 4,000,000,000 | 34. | 40.04 |
| 35. | -123.123 | 36. | -2382 | 37. | -0.00234 |

Express each quantity in decimal notation.

- | | | | | | |
|-----|-----------------------|-----|---------------------|-----|-------------------------|
| 38. | 2×10^3 | 39. | 3×10^{-4} | 40. | 1.53×10^5 |
| 41. | 9.75×10^{-3} | 42. | 4.23×10^8 | 43. | -0.001×10^{-3} |
| 44. | -8.75×10^0 | 45. | -3.26×10^3 | 46. | -3.26×10^{-3} |

Perform the indicated operation and express your answer in scientific notation.

- | | | | | | |
|-----|----------------------------------|-----|--|-----|--|
| 47. | $(2 \times 10^5)(3 \times 10^7)$ | 48. | $\frac{12 \times 10^{-4}}{4 \times 10^2}$ | 49. | $(3.2 \times 10^{-4})(5 \times 10^{-6})$ |
| 50. | $\frac{0.0000049}{0.00007}$ | 51. | $\frac{0.012 \times 10^{-7}}{3.0 \times 10^{-13}}$ | 52. | $(5,000,000)(0.00002)$ |

- | | | | |
|----------------------------|--------------------------|----------------------------|------------------------|
| 1. a^3b^5 | 2. $-27x^6y^3$ | 3. $64x^6$ | 4. $2r^9s^8$ |
| 5. x^{3n} | 6. $\frac{s^2}{r^6}$ | 7. $\frac{1}{a^2}$ | 8. $\frac{1}{x^7y^5}$ |
| 9. $4a^4b$ | 10. $\frac{y^2}{x^6}$ | 11. $-\frac{8x^3}{y^6}$ | 12. $\frac{4x^2}{y^4}$ |
| 13. $\frac{z^6}{18y^4}$ | 14. $\frac{4b^4}{a^2}$ | 15. $\frac{4b^7}{c^5}$ | 16. $\frac{c^4}{8a^2}$ |
| 17. a | 18. c^4 | 19. $\frac{1}{(x-y)^5}$ | 20. y |
| 21. $\frac{1}{a+b}$ | 22. a^2 | 23. 1 | 24. $a+b$ |
| 25. -1 | 26. $1+x^2$ | 27. $\frac{xy}{y-x}$ | 28. $\frac{1}{a+1}$ |
| 29. 3.5×10^3 | 30. 4×10^{-3} | 31. 4.612×10^6 | |
| 32. 5.6×10^{-5} | 33. 4×10^9 | 34. 4.004×10^1 | |
| 35. -1.23123×10^2 | 36. -2.382×10^3 | 37. -2.34×10^{-3} | |
| 38. 2000 | 39. 0.0003 | 40. $153,000$ | |
| 41. 0.00975 | 42. $423,000,000$ | 43. -0.000001 | |
| 44. -8.75 | 45. -3260 | 46. -0.00326 | |
| 47. 6×10^{12} | 48. 3×10^{-6} | 49. 1.6×10^{-9} | |
| 50. 7×10^{-2} | 51. 4×10^3 | 52. 1×10^2 | |

§2-2**POLYNOMIAL EXPRESSIONS****Definition**

Terms with exactly the same variable parts (the same variables raised to the same powers) are called **like terms**. Terms with different variable parts are called **unlike terms**.

Example 1

Simplify the polynomial expression $7x^2 + 3xy - 4x^2 + xy - y^2$ by combining like terms.

Solution

$$\begin{aligned} 7x^2 + 3xy - 4x^2 + xy - y^2 &= 7x^2 - 4x^2 + 3xy + xy - y^2 \\ &= (7 - 4)x^2 + (3 + 1)xy - y^2 \\ &= 3x^2 + 4xy - y^2 \end{aligned}$$

Example 2

Given $x = -2$ and $y = 3$, what is the value of $xy^2 - 2xy$.

Solution

$$\begin{aligned} xy^2 - 2xy &= (-2)(3)^2 - 2(-2)(3) \\ &= (-2)(9) - 2(-6) \\ &= -18 + 12 \\ &= -6 \end{aligned}$$

Procedure**Multiplying Polynomials**

Two polynomials are multiplied together by multiplying each term of the first polynomial by each term of the second polynomial and then summing the products.

Example 3

Find the product of $(x^2 - y)(2x + y^2 - 3)$.

Solution

$$\begin{aligned} (x^2 - y)(2x + y^2 - 3) &= (x^2)(2x) + (x^2)(y^2) - (x^2)(3) - (y)(2x) - (y)(y^2) + (y)(3) \\ &= 2x^3 + x^2y^2 - 3x^2 - 2xy - y^3 + 3y \end{aligned}$$

Formulas**Description**

Difference of two squares

Perfect Square Trinomials

Sum of two cubes

Difference of two cubes

Formula

$$a^2 - b^2 = (a - b)(a + b)$$

$$a^2 + 2ab + b^2 = (a + b)^2$$

$$a^2 - 2ab + b^2 = (a - b)^2$$

$$a^3 + b^3 = (a + b)(a^2 - ab + b^2)$$

$$a^3 - b^3 = (a - b)(a^2 + ab + b^2)$$

Example 4

Factor $9x^2 - 64y^2$.

Solution

Since the expression $9x^2 - 64y^2$ is the difference of two squares we have

$$\begin{aligned} 9x^2 - 64y^2 &= (3x)^2 - (8y)^2 \\ &= (3x - 8y)(3x + 8y) \end{aligned}$$

Example 5

Factor $16m^2 - 16mn^2 + 4n^4$.

Solution

$$\begin{aligned} 16m^2 - 16mn^2 + 4n^4 &= 4[4m^2 - 4mn^2 + n^4] \\ &= 4[(2m)^2 - 2 \cdot (2m)(n^2) + (n^2)^2] \\ &= 4(2m - n^2)^2 \end{aligned}$$

Evaluate each polynomial for the given values.

- | | |
|---|--|
| 1. $3x^2 + 2$ where $x = 1$ | 2. $-x^2$ where $x = -2$ |
| 3. $2x^2 + 3x - 3$ where $x = -2$ | 4. $4t^2 - 6t + 2$ where $t = \frac{1}{2}$ |
| 5. $x^2y - 2x + 1$ where $x = -1$ and $y = 3$ | 6. $3ab - 2b^2 + 2$ where $a = 2$ and $b = -2$ |

Simplify by combining like terms.

- | | |
|---|---|
| 7. $(7x - 2) + (5x + 22)$ | 8. $(3y + 4) - (4y - 12)$ |
| 9. $(3x^2 - 2x + 7) + (x^2 + 4x - 2)$ | 10. $(5x^2 + 3x - 1) - (2x^2 - 4x - 2)$ |
| 11. $(2a^2b + 5ab^2) + (ab^2 + 3ab - a^2b)$ | 12. $(5b^3 - ab + 4a^2) - (a^2 - b - ab)$ |
| 13. $(3x^2 - 2x + 5) + (-3x^2 + 2x + 1)$ | 14. $(xy^2 + y - 2) - (x^2y + 2x + y)$ |

Multiply and then simplify.

- | | |
|-----------------------------|------------------------------------|
| 15. $4x^2(2x - 9)$ | 16. $4y^2(3y^2 - 5y + 7)$ |
| 17. $4a^2(5b^2 - 3b + 4)$ | 18. $(2x + 3)(x - 1)$ |
| 19. $(x - 2)(x^2 + 2x - 1)$ | 20. $3(t - 6)(t^2 - t + 3)$ |
| 21. $(x - 5)(x + 1)^2$ | 22. $(2r^2 - r + 7)(r^2 + 2r - 3)$ |

Factor completely.

- | | |
|-----------------------------|--------------------------------|
| 23. $x^2 - 9$ | 24. $64r^2 - 25s^2$ |
| 25. $4x^2 + 16$ | 26. $98x^3 - 50x$ |
| 27. $9x^2 - 60x + 100$ | 28. $25x^2 + 40x + 16$ |
| 29. $27x^4 + 72x^3 + 48x^2$ | 30. $45a^3 + 60a^2 + 20a$ |
| 31. $64x^2 - 80xy + 25y^2$ | 32. $16a^4 - 72a^2b^2 + 81b^4$ |
| 33. $x^2 + 4$ | 34. $x^3 + 8$ |
| 35. $x^3 - 27$ | 36. $5x^5 + 40x^2$ |
| 37. $4t^4 - 32t$ | 38. $3y^3 + 27y$ |
| 39. $64r^3 + 27s^3$ | 40. $a^3 + 8b^6$ |

1. 5
2. -4
3. -1
4. 0
5. 6
6. -18
7. $12x + 20$
8. $-y + 16$
9. $4x^2 + 2x + 5$
10. $3x^2 + 7x + 1$
11. $a^2b + 3ab + 6ab^2$
12. $5b^3 + 3a^2 + b$
13. 6
14. $xy^2 - x^2y - 2x - 2$
15. $8x^3 - 36x^2$
16. $12y^4 - 20y^3 + 28y^2$
17. $20a^2b^2 - 12a^2b + 16a^2$
18. $2x^2 + x - 3$
19. $x^3 - 5x + 2$
20. $3t^3 - 21t^2 + 27t - 54$
21. $x^3 - 3x^2 - 9x - 5$
22. $2r^4 + 3r^3 - r^2 + 17r - 21$
23. $(x - 3)(x + 3)$
24. $(8r - 5s)(8r + 5s)$
25. $4(x^2 + 4)$
26. $2x(7x + 5)(7x - 5)$
27. $(3x - 10)^2$
28. $(5x + 4)^2$
29. $3x^2(3x + 4)^2$
30. $5a(3a + 2)^2$
31. $(8x - 5y)^2$
32. $(2a + 3b)^2(2a - 3b)^2$
33. $x^2 + 4$
34. $(x + 2)(x^2 - 2x + 4)$
35. $(x - 3)(x^2 + 3x + 9)$
36. $5x^2(x + 2)(x^2 - 2x + 4)$
37. $4t(t - 2)(t^2 + 2t + 4)$
38. $3y(y^2 + 9)$
39. $(4r + 3s)(16r^2 - 12rs + 9s^2)$
40. $(a + 2b^2)(a^2 - 2ab^2 + 4b^4)$

§2-3**RATIONAL EXPRESSIONS****Definition**

A **rational expression** has the form $\frac{P}{Q}$, where P and Q are polynomials and $Q \neq 0$.

Property

If $\frac{P}{Q}$ is a rational expression and if R is a polynomial such that $R \neq 0$, then $\frac{PR}{QR} = \frac{P}{Q}$.

Example 1

Simplify the rational expression: $\frac{2x - 10}{2x^2 - 20x + 50}$.

Solution

$$\begin{aligned} \frac{2x - 10}{2x^2 - 20x + 50} &= \frac{2(x - 5)}{2(x^2 - 10x + 25)} \\ &= \frac{2(x - 5)}{2(x - 5)^2} \\ &= \frac{1}{x - 5} \end{aligned}$$

Procedure**Multiplying Rational Expressions**

The product of the rational expressions $\frac{P}{Q}$ and $\frac{R}{S}$ is $\frac{P}{Q} \cdot \frac{R}{S} = \frac{PR}{QS}$.

Example 2

Multiply the following rational expressions: $\left(1 + \frac{1}{x}\right)\left(\frac{3}{x+1}\right)$. Simplify your answer.

Solution

$$\begin{aligned} \left(1 + \frac{1}{x}\right)\left(\frac{3}{x+1}\right) &= \left(\frac{x}{x} + \frac{1}{x}\right)\left(\frac{3}{x+1}\right) \\ &= \left(\frac{x+1}{x}\right)\left(\frac{3}{x+1}\right) \\ &= \frac{3(x+1)}{x(x+1)} \\ &= \frac{3}{x} \end{aligned}$$

Procedure**Dividing Rational Expressions**

The quotient of the rational expressions $\frac{P}{Q}$ and $\frac{R}{S}$ is $\frac{P}{Q} \div \frac{R}{S} = \frac{P}{Q} \cdot \frac{S}{R} = \frac{PS}{QR}$.

Example 3

Divide the following rational expressions $\frac{x^2 - x}{3} \div \frac{1}{3x}$. Simplify your answer.

Solution

$$\begin{aligned} \frac{x^2 - x}{3} \div \frac{1}{3x} &= \frac{x(x-1)}{3} \cdot \frac{3x}{1} \\ &= \frac{3x^2(x-1)}{3} \\ &= x^2(x-1) \end{aligned}$$

Procedure**Adding Rational Expressions**

If $\frac{P}{Q}$ and $\frac{R}{Q}$ are rational expressions, then $\frac{P}{Q} + \frac{R}{Q} = \frac{P+R}{Q}$.

Example 4

Add the following rational expressions: $\frac{2x}{x^2-1} + \frac{-1}{x-1}$. Simplify your answer.

Solution

$$\begin{aligned} \frac{2x}{x^2-1} + \frac{-1}{x-1} &= \frac{2x}{(x-1)(x+1)} + \frac{-1}{x-1} \\ &= \frac{2x}{(x-1)(x+1)} + \frac{-1}{(x-1)} \cdot \frac{(x+1)}{(x+1)} \\ &= \frac{2x-(x+1)}{(x-1)(x+1)} \\ &= \frac{2x-x-1}{(x-1)(x+1)} \\ &= \frac{x-1}{(x-1)(x+1)} \\ &= \frac{1}{x+1} \end{aligned}$$

Procedure**Subtracting Rational Expressions**

If $\frac{P}{Q}$ and $\frac{R}{Q}$ are rational expressions, then $\frac{P}{Q} - \frac{R}{Q} = \frac{P-R}{Q}$.

Example 5

Subtract the following rational expressions: $\frac{1}{x^2-x-6} - \frac{2}{x^2+4x-21}$.

Solution

$$\begin{aligned} \frac{1}{x^2-x-6} - \frac{2}{x^2+4x-21} &= \frac{1}{(x-3)(x+2)} - \frac{2}{(x-3)(x+7)} \\ &= \frac{1 \cdot (x+7)}{(x-3)(x+2)(x+7)} - \frac{2 \cdot (x+2)}{(x-3)(x+7)(x+2)} \\ &= \frac{(x+7) - (2x+4)}{(x-3)(x+2)(x+7)} \\ &= \frac{x+7-2x-4}{(x-3)(x+2)(x+7)} \\ &= \frac{-(x-3)}{(x-3)(x+2)(x+7)} \\ &= \frac{-1}{(x+2)(x+7)} \\ &= \frac{-1}{x^2+9x+14} \end{aligned}$$

Simplify each expression.

1. $\frac{18xy}{12x}$

2. $\frac{(a+3)(a-2)}{(a+2)(a+3)}$

3. $\frac{3x-6}{9x}$

4. $\frac{3x^2+2x}{x}$

5. $\frac{h^2-16}{h+4}$

6. $\frac{x^2+2x}{x+2}$

7. $\frac{c^2+2c+1}{c^2-1}$

8. $\frac{z^2+4z}{z^2-2z}$

9. $\frac{(2t-1)(t+2)}{4t^2-4t+1}$

10. $\frac{x^2+6x+9}{x^3+27}$

11. $\frac{9x^2-4}{27x^3-8}$

12. $\frac{9m^2-16}{27m^3-64}$

Perform the indicated operation and simplify the result.

13. $\frac{a}{y} \cdot \frac{x}{a}$

14. $\frac{r}{s} \div \frac{t}{s}$

15. $\frac{2x}{3y} \cdot \frac{y^2}{4x}$

16. $\frac{14b}{9a} \div \frac{7a}{3}$

17. $\frac{12(t-1)}{t^2+1} \div \frac{t^2-1}{t+1}$

18. $\frac{3x^2+2x}{x-2} \cdot \frac{x-2}{x}$

19. $\frac{6y-2}{y} \cdot \frac{6y}{6y+3}$

20. $\frac{t+2}{t^2+3t} \div \frac{t+2}{t+3}$

21. $\frac{4k-8}{k+1} \div \frac{2k-10}{k+1}$

22. $\frac{5x^2+2x}{x-2} \div \frac{5x+2}{4x-8}$

23. $\frac{a^2+ab}{b} \cdot \frac{b}{a^2-ab}$

24. $\frac{10}{x+2} \cdot \frac{x^2+2x}{4x+6}$

25. $\frac{9x^2-4}{27x^3-8} \div \frac{3x+2}{3x-2}$

26. $\frac{x^2-x}{4x^2-9} \div \frac{x-1}{2x+3}$

27. $\frac{x^2+10x+25}{x-4} \cdot \frac{3x-12}{2x+10}$

28. $\frac{3}{a} + \frac{2}{b}$

29. $\frac{5}{x+2} + \frac{x}{x+2}$

30. $\frac{9}{2x+1} - \frac{5}{2x+1}$

31. $\frac{9}{r} + \frac{8}{r}$

32. $\frac{x}{z} + \frac{z}{y}$

33. $\frac{5}{xy} - 3$

34. $\frac{8}{m+3} + \frac{2}{m}$

35. $\frac{b}{b-2} + \frac{4}{b-3}$

36. $\frac{n}{n+3} + \frac{3}{n+3}$

37. $\frac{z}{z+2} - \frac{4}{z-2}$

38. $\frac{10}{x-y} - \frac{2}{y-x}$

39. $\frac{3}{x} + \frac{2}{x-2}$

40. $\frac{t}{t+2} + \frac{2}{t-1}$

41. $\frac{2x}{x-1} - \frac{5}{x+1}$

42. $\frac{y+2}{y^2-4} + \frac{y^2+2y+4}{y^3-8}$

1. $\frac{3y}{2}$

2. $\frac{a-2}{a+2}$

3. $\frac{x-2}{3x}$

4. $3x+2$

5. $h-4$

6. x

7. $\frac{c+1}{c-1}$

8. $\frac{z+4}{z-2}$

9. $\frac{t+2}{2t-1}$

10. $\frac{x+3}{x^2+3x+9}$

11. $\frac{3x+2}{9x^2-6x+4}$

12. $\frac{3m+4}{9m^2-12m+16}$

13. $\frac{x}{y}$

14. $\frac{r}{t}$

15. $\frac{y}{6}$

16. $\frac{2b}{3a^2}$

17. $\frac{12}{t^2+1}$

18. $3x+2$

19. $\frac{12y-4}{2y+1}$

20. $\frac{1}{t}$

21. $\frac{2k-4}{k-5}$

22. $4x$

23. $\frac{a+b}{a-b}$

24. $\frac{5x}{2x+3}$

25. $\frac{3x-2}{9x^2-6x+4}$

26. $\frac{x}{2x-3}$

27. $\frac{3x+15}{2}$

28. $\frac{2a+3b}{ab}$

29. $\frac{x+5}{x+2}$

30. $\frac{4}{2x+1}$

31. $\frac{17}{r}$

32. $\frac{z^2+xy}{yz}$

33. $\frac{5-3xy}{xy}$

34. $\frac{10m+6}{m^2+3m}$

35. $\frac{b^2+b-8}{b^2-5b+6}$

36. 1

37. $\frac{z-4}{z-2}$

38. $\frac{12}{x-y}$

39. $\frac{5x-6}{x^2-2x}$

40. $\frac{t^2+t+4}{t^2+t-2}$

41. $\frac{2x^2-3x+5}{x^2-1}$

42. $\frac{2}{y-2}$

§2-4**RADICAL EXPRESSIONS****Definition**

The **n th root** of a number a is a number that when raised to the n th power, produces the number a . It is written as $\sqrt[n]{a}$, where n is the **index**, $\sqrt{\quad}$ is the **radical** and a is the **radicand**.

For example, $\sqrt{9} = 3$ since $3^2 = 9$ and $\sqrt{x^6} = x^3$ since $(x^3)^2 = x^6$.
Similarly, $\sqrt[4]{16} = 2$ since $2^4 = 16$ and $\sqrt[3]{x^{12}} = x^4$ since $(x^4)^3 = x^{12}$.

Definition

Rational exponents are exponents of the form $\frac{m}{n}$, where m is the power of the number and n represents the n th root of the number. Thus $a^{m/n} = \sqrt[n]{a^m} = (\sqrt[n]{a})^m$ where $a \geq 0$.

For example, $27^{1/3} = \sqrt[3]{27} = 3$ and $8^{2/3} = (\sqrt[3]{8})^2 = (2)^2 = 4$

Example 1

Write the expression $x^{2/3}$ in radical form.

Solution

The expression $x^{2/3}$ can be written as $(x^{1/3})^2$ or $(x^2)^{1/3}$.
Therefore, $x^{2/3}$ can be written in radical form as $(\sqrt[3]{x})^2$ or $\sqrt[3]{x^2}$.

Example 2

Simplify the expression $\sqrt{18} - \sqrt{8}$.

Solution

$$\sqrt{18} - \sqrt{8} = \sqrt{9 \cdot 2} - \sqrt{4 \cdot 2} = 3\sqrt{2} - 2\sqrt{2} = (3 - 2)\sqrt{2} = \sqrt{2}$$

Example 3

Simplify the expression $\sqrt[3]{x^7 y^5 z^6} - \sqrt[3]{x^{10} y^8 z^3}$.

Solution

$$\begin{aligned} \sqrt[3]{x^7 y^5 z^6} - \sqrt[3]{x^{10} y^8 z^3} &= \sqrt[3]{x^6 \cdot x \cdot y^3 \cdot y^2 \cdot z^6} - \sqrt[3]{x^9 \cdot x \cdot y^6 \cdot y^2 \cdot z^3} \\ &= (x^2 y z^2) \sqrt[3]{xy^2} - (x^3 y^2 z) \sqrt[3]{xy^2} \\ &= (x^2 y z^2 - x^3 y^2 z) \sqrt[3]{xy^2} \\ &= x^2 y z (z - xy) \sqrt[3]{xy^2} \end{aligned}$$

Example 4

Multiply $(\sqrt{2} - \sqrt{3})(\sqrt{8} - \sqrt{4})$.

Solution

$$\begin{aligned} (\sqrt{2} - \sqrt{3})(\sqrt{8} - \sqrt{4}) &= \sqrt{2} \cdot \sqrt{8} - \sqrt{2} \cdot \sqrt{4} - \sqrt{3} \cdot \sqrt{8} + \sqrt{3} \cdot \sqrt{4} \\ &= \sqrt{16} - \sqrt{8} - \sqrt{24} + \sqrt{12} \\ &= 4 - \sqrt{4 \cdot 2} - \sqrt{4 \cdot 6} + \sqrt{4 \cdot 3} \\ &= 4 - 2\sqrt{2} - 2\sqrt{6} + 2\sqrt{3} \end{aligned}$$

Write each exponential expression as a radical expression.

1. $5^{1/2}$ 2. $(2x)^{1/3}$ 3. $(xy^3)^{3/4}$ 4. $-5x^{2/3}$ 5. $(a^2b^4)^{1/5}$

Write each radical expression as a exponential expression.

6. $\sqrt{11}$ 7. $\sqrt[5]{a^3}$ 8. $-\sqrt{2y}$ 9. $4x\sqrt{x}$ 10. $2r^4\sqrt[4]{2s^3}$

Simplify each radical expression.

11. $\sqrt{64}$ 12. $\sqrt[3]{64}$ 13. $\sqrt[3]{-1}$ 14. $\sqrt[3]{-27}$ 15. $\sqrt{\frac{4}{9}}$

16. $\sqrt{x^{12}}$ 17. $-\sqrt{a^{12}b^4}$ 18. $\sqrt[3]{8x^6y^9}$ 19. $\sqrt[4]{16r^8}$ 20. $\sqrt[5]{-x^5y^{10}}$

21. $\sqrt[3]{-27a^9}$ 22. $\sqrt[5]{243x^{15}y^{25}}$ 23. $\sqrt{\frac{25x^2}{y^4}}$ 24. $\sqrt[3]{\frac{27a^{12}}{b^{15}}}$

25. $\sqrt{(x+y)^2}$ 26. $\sqrt[3]{(x+y)^6}$ 27. $3\sqrt{5} + 2\sqrt{5}$ 28. $3\sqrt{5} - 2\sqrt{5}$

29. $2\sqrt{12} - 3\sqrt{3}$ 30. $a\sqrt{7} - b\sqrt{7}$ 31. $3 \cdot \sqrt[3]{16} - \sqrt[3]{2}$ 32. $\sqrt{x^3} - 2x\sqrt{x}$

33. $\sqrt{x} + \sqrt{x}$ 34. $\sqrt{x} \cdot \sqrt{x}$ 35. $3\sqrt{2} \cdot \sqrt{3}$ 36. $\sqrt{x+y} \cdot \sqrt{x+y}$

37. $\sqrt{6x} \cdot \sqrt{12x}$ 38. $\frac{2}{\sqrt{2}}$ 39. $\frac{x}{\sqrt{x}}$ 40. $\frac{2x}{\sqrt{8x^3}}$

41. $\sqrt[3]{\sqrt{64}}$ 42. $\sqrt[3]{\sqrt{x}}$ 43. $\sqrt[3]{\sqrt{x^{12}}}$ 44. $\sqrt[3]{\sqrt[4]{ab^2}}$

45. $\frac{5\sqrt{x}}{y^2} \cdot \frac{\sqrt{25y}}{\sqrt{x^3}}$ 46. $\frac{\sqrt{3y}}{4\sqrt{4x}} \cdot \frac{x}{y\sqrt{y}}$ 47. $\frac{5\sqrt{x}}{y^2} \div \frac{\sqrt{25y}}{\sqrt{x^3}}$ 48. $\frac{\sqrt{3y}}{4\sqrt{4x}} \div \frac{x}{y\sqrt{y}}$

49. $\frac{4}{\sqrt{2}} + \frac{3}{\sqrt{2}}$ 50. $\frac{4}{\sqrt{2}} - \frac{3}{\sqrt{2}}$ 51. $\frac{\sqrt{27}}{\sqrt{12}} + \frac{2}{\sqrt[3]{27}}$

52. $\frac{2}{\sqrt{12}} - \frac{3}{\sqrt{3}}$ 53. $\frac{2}{\sqrt{12}} + \frac{3}{\sqrt{3}}$ 54. $\frac{\sqrt{27}}{\sqrt{12}} - \frac{2}{\sqrt[3]{27}}$

55. $\sqrt{2}(\sqrt{10} + \sqrt{5})$ 56. $\sqrt{3}(\sqrt{8} - \sqrt{6})$ 57. $\frac{2}{\sqrt{3} - \sqrt{2}}$

58. $\frac{2}{\sqrt{3} + \sqrt{2}}$ 59. $\frac{3}{\sqrt{3} + \sqrt{2}} + \frac{1}{\sqrt{3} - \sqrt{2}}$ 60. $\frac{2}{\sqrt{2} + \sqrt{5}} - \frac{3}{\sqrt{2} - \sqrt{5}}$

- | | | | | | | | | | |
|-----|-------------------------|-----|----------------------------------|-----|-----------------------------|-----|--------------------------|-----|---------------------------|
| 1. | $\sqrt{5}$ | 2. | $\sqrt[3]{2x}$ | 3. | $y^2 \cdot \sqrt[4]{x^3y}$ | 4. | $-5 \cdot \sqrt[3]{x^2}$ | 5. | $\sqrt[5]{a^2b^4}$ |
| 6. | $11^{1/2}$ | 7. | $a^{3/5}$ | 8. | $-(2y)^{1/2}$ | 9. | $4x^{3/2}$ | 10. | $(2^{7/4})(r)(s^{3/4})$ |
| 11. | 8 | 12. | 4 | 13. | -1 | 14. | -3 | 15. | $\frac{2}{3}$ |
| 16. | x^6 | 17. | $-a^6b^2$ | 18. | $2x^2y^3$ | 19. | $2r^2$ | 20. | $-xy^2$ |
| 21. | $-3a^3$ | 22. | $3x^3y^5$ | 23. | $\frac{5x}{y^2}$ | 24. | $\frac{3a^4}{b^5}$ | 25. | $x + y$ |
| 26. | $(x + y)^2$ | 27. | $5\sqrt{5}$ | 28. | $\sqrt{5}$ | 29. | $\sqrt{3}$ | 30. | $(a - b)\sqrt{7}$ |
| 31. | $5 \cdot \sqrt[3]{2}$ | 32. | $-x\sqrt{x}$ | 33. | $2\sqrt{x}$ | 34. | x | 35. | $3\sqrt{6}$ |
| 36. | $x + y$ | 37. | $2x\sqrt{18}$ | 38. | $\sqrt{2}$ | 39. | \sqrt{x} | 40. | $\frac{\sqrt{2x}}{2x}$ |
| 41. | 2 | 42. | $\sqrt[6]{x}$ | 43. | x^2 | 44. | $\sqrt[24]{ab^2}$ | 45. | $\frac{25\sqrt{y}}{xy^2}$ |
| 46. | $\frac{\sqrt{3x}}{8y}$ | 47. | $\frac{x^2\sqrt{y}}{y^3}$ | 48. | $\frac{y^2\sqrt{3x}}{8x^2}$ | 49. | $\frac{7\sqrt{2}}{2}$ | 50. | $\frac{\sqrt{2}}{2}$ |
| 51. | $\frac{13}{6}$ | 52. | $-\frac{2\sqrt{3}}{3}$ | 53. | $\frac{4\sqrt{3}}{3}$ | 54. | $\frac{5}{6}$ | 55. | $2\sqrt{5} + \sqrt{10}$ |
| 56. | $2\sqrt{6} - 3\sqrt{2}$ | 57. | $2\sqrt{3} + 2\sqrt{2}$ | 58. | $2\sqrt{3} - 2\sqrt{2}$ | | | | |
| 59. | $4\sqrt{3} - 2\sqrt{2}$ | 60. | $\frac{\sqrt{2} + 5\sqrt{5}}{3}$ | | | | | | |

§3-1**LINEAR EQUATIONS****Definition**

Linear equations in one variable are equations which can be written in the form $ax + b = 0$ where a and b are real numbers.

Property**The Addition Property of Equations**

If $a = b$ and c is a real number then $a + c = b + c$.

Property**The Multiplication Property of Equations**

If $a = b$ and c is a real number then $ac = bc$.

Example 1

Solve the equation for x : $5x + 15 = 0$.

Solution

$$\begin{aligned}5x + 15 &= 0 \\5x + 15 - 15 &= 0 - 15 \\5x &= -15 \\ \frac{5x}{5} &= \frac{-15}{5} \\x &= -3\end{aligned}$$

Example 2

Solve the equation for x : $4x + 5 = 6$.

Solution

$$\begin{aligned}4x + 5 &= 6 \\4x + 5 - 5 &= 6 - 5 \\4x &= 1 \\ \frac{4x}{4} &= \frac{1}{4} \\x &= \frac{1}{4}\end{aligned}$$

Example 3

Solve the equation for x : $3x - 5 = x + 1$.

Solution

$$\begin{aligned}3x - 5 &= x + 1 \\3x - 5 - x &= x + 1 - x \\2x - 5 &= 1 \\2x - 5 + 5 &= 1 + 5 \\2x &= 6 \\ \frac{2x}{2} &= \frac{6}{2} \\x &= 3\end{aligned}$$

Example 4

Solve the equation for x : $ax + b = c$.

Solution

$$\begin{aligned}ax + b &= c \\ax + b - b &= c - b \\ax &= c - b \\ \frac{ax}{a} &= \frac{c - b}{a} \\x &= \frac{c - b}{a}\end{aligned}$$

Example 5 Solve the equation for x : $\frac{1}{2}x - \frac{1}{3} = \frac{5}{6}x + 1$.

Solution

$$\begin{aligned}\frac{1}{2}x - \frac{1}{3} + \frac{1}{3} &= \frac{5}{6}x + 1 + \frac{1}{3} \\ \frac{1}{2}x &= \frac{5}{6}x + \frac{4}{3} \\ \frac{3}{6}x - \frac{5}{6}x &= \frac{5}{6}x + \frac{4}{3} - \frac{5}{6}x \\ -\frac{2}{6}x &= \frac{4}{3} \\ -\frac{1}{3}x &= \frac{4}{3} \\ (-3)\left(-\frac{1}{3}x\right) &= \frac{4}{3} \cdot (-3) \\ x &= -4\end{aligned}$$

Example 6 Solve the equation for x : $-16x + 7 = 2x - 2$.

Solution

$$\begin{aligned}-16x + 7 &= 2x - 2 \\ -16x + 7 - 7 &= 2x - 2 - 7 \\ -16x &= 2x - 9 \\ -16x + 7 - 2x &= 2x - 2 - 2x \\ -18x &= 9 \\ \frac{-18x}{-18} &= \frac{-9}{-18} \\ x &= \frac{1}{2}\end{aligned}$$

Example 7 Solve the equation for x : $(x - 3)^2 = x^2 + 3$.

Solution

$$\begin{aligned}(x - 3)^2 &= x^2 + 3 \\ x^2 - 6x + 9 &= x^2 + 3 \\ x^2 - 6x + 9 - x^2 &= x^2 + 3 - x^2 \\ -6x + 9 &= 3 \\ -6x + 9 - 9 &= 3 - 9 \\ -6x &= -6 \\ \frac{-6x}{-6} &= \frac{-6}{-6} \\ x &= 1\end{aligned}$$

Example 8 Three more than twice a number x is equal to y . Solve the equation for x .

Solution

$$\begin{aligned}2x + 3 &= y \\ 2x + 3 - 3 &= y - 3 \\ 2x &= y - 3 \\ \frac{2x}{2} &= \frac{y - 3}{2} \\ x &= \frac{y - 3}{2}\end{aligned}$$

Solve each equation.

1. $4x = 36$

2. $x + 12 = 64$

3. $x - 6 = 43$

4. $\frac{x}{4} = 8$

5. $\frac{2x}{3} = 6$

6. $\frac{x}{9} - 5 = 40$

7. $\frac{5x}{2} = 10$

8. $13x + 57 = 182$

9. $14 = 3x - 4$

10. $5(b - 3) = 7$

11. $4 + 6(r + 2) = 9$

12. $12x - 3 = 8x - 9$

13. $6s + 8 = 8 - 5s$

14. $\frac{2 + 9x}{6} = 12$

15. $\frac{7 - 2s}{3} = 2$

16. $\frac{x}{3} + 1 = 22$

17. $\frac{3y}{4} + 7 = 10$

18. $\frac{3t}{2} - 10 = 6$

19. $0.3c + 1.5 = 0.8c$

20. $0.1(v - 8) = 10$

21. $\frac{3w}{2} - \frac{5}{6} = \frac{w}{3}$

22. $41.7x - 13.2 = 91.8$

23. $\frac{2}{3}t + 8 = \frac{5}{4}t$

24. $6(k + 10) = 5(k + 14)$

25. $3t - 7 = 8t + 5$

26. $1.83 = 7x - 4.19$

27. $r + \frac{1}{3} = \frac{2}{3}r + \frac{5}{6}$

28. $8 - 9a = 9a - 8$

29. $\frac{3}{5}(2t - 4) = \frac{1}{5}t$

30. $4(1 - b) = 2(b + 14)$

31. $\frac{5x}{2} + 2 = 3x - 1$

32. $3a + 2 = \frac{a}{5} - 4$

33. $5 - x = \frac{2x}{3} - 6$

34. $\frac{x}{2} - \frac{2}{3} = \frac{1}{4}$

35. $\frac{2x}{3} - \frac{1}{2} = \frac{1}{4}$

36. $\frac{2x}{3} - 2 = \frac{1}{5}$

Solve for x .

37. $ax + cd = h$

38. $a(b + x) = d$

39. $2r + 3x = 6$

40. $5x - 6 = 3q + 4$

41. $8 - 3x = 2r - 7$

42. $5(x + 2s) = 2x$

Write an equation that represents each word statement. Solve the equation for x .

43. Two more than three times a number x is equal to 7.

44. Two more than three times a number x is equal to -3 .

45. Three less than four times a number x is equal to y .

- | | | | | | | | | | |
|-----|---------------------------|-----|---------------------------|-----|-------------------------|-----|------------------|-----|-------------------|
| 1. | 9 | 2. | 52 | 3. | 49 | 4. | 32 | 5. | 9 |
| 6. | 5 | 7. | 4 | 8. | $\frac{125}{13}$ | 9. | 6 | 10. | $\frac{22}{5}$ |
| 11. | $-\frac{7}{6}$ | 12. | $-\frac{3}{2}$ | 13. | 0 | 14. | $\frac{70}{9}$ | 15. | $\frac{1}{2}$ |
| 16. | 63 | 17. | 4 | 18. | $\frac{32}{3}$ | 19. | 3 | 20. | 108 |
| 21. | $\frac{5}{7}$ | 22. | $\frac{350}{139}$ | 23. | $\frac{96}{7}$ | 24. | 10 | 25. | $-\frac{12}{5}$ |
| 26. | 0.86 | 27. | $\frac{3}{2}$ | 28. | $\frac{8}{9}$ | 29. | $\frac{12}{5}$ | 30. | -4 |
| 31. | 6 | 32. | $-\frac{15}{7}$ | 33. | $\frac{33}{5}$ | 34. | $\frac{11}{6}$ | 35. | $\frac{9}{8}$ |
| 36. | $\frac{33}{10}$ | 37. | $\frac{h-cd}{a}$ | 38. | $\frac{d-ab}{a}$ | 39. | $\frac{6-2r}{3}$ | 40. | $\frac{3q+10}{5}$ |
| 41. | $\frac{15-2r}{3}$ | 42. | $-\frac{10s}{3}$ | 43. | $3x+2=7; x=\frac{5}{3}$ | | | | |
| 44. | $3x+2=-3; x=-\frac{5}{3}$ | 45. | $4x-3=y; x=\frac{y+3}{4}$ | | | | | | |

§3-2**QUADRATIC EQUATIONS****Definition**

Quadratic equations in one variable are equations which can be written in the form $ax^2 + bx + c = 0$ where a , b and c are real numbers and $a \neq 0$.

Quadratic equations can have two real solutions, one real solution or no real solutions. They can often be solved by factoring and applying the zero-product property.

Property**The Zero-product Property**

For any two real numbers a and b if $ab = 0$ then $a = 0$ or $b = 0$.

Example 1

Solve the equation for x , $x^2 = x + 2$.

Solution

$$\begin{aligned}x^2 &= x + 2 \\x^2 - x - 2 &= 0 \\(x - 2)(x + 1) &= 0 \\x - 2 = 0 &\quad \text{or} \quad x + 1 = 0 \\x = 2 &\quad \quad \quad x = -1\end{aligned}$$

Example 2

Solve the equation for x , $3x^2 - 6x + 4 = -x^2 + 6x - 5$.

Solution

$$\begin{aligned}3x^2 - 6x + 4 &= -x^2 + 6x - 5 \\4x^2 - 12x + 9 &= 0 \\(2x - 3)^2 &= 0 \\\sqrt{(2x - 3)^2} &= \pm\sqrt{0} \\2x - 3 &= 0 \\2x &= 3 \\x &= \frac{3}{2}\end{aligned}$$

Example 3

Solve the equation for x , $2x^2 + 18 = 0$.

Solution

$$\begin{aligned}2x^2 + 18 &= 0 \\2x^2 &= -18 \\x^2 &= -9 \\\sqrt{x^2} &= \pm\sqrt{-9} \\x &= \pm 3i\end{aligned}$$

Thus there are no real solutions.

For some quadratic equations it is necessary to use the *quadratic formula*.

Formula

The Quadratic Formula

For any quadratic equation $ax^2 + bx + c = 0$, $x = \frac{-b \pm \sqrt{b^2 - 4ac}}{2a}$.

Example 4 Solve the quadratic equation for x : $2x^2 + 3x - 5 = 0$.

Solution
$$x = \frac{-b \pm \sqrt{b^2 - 4ac}}{2a} = \frac{-3 \pm \sqrt{(3)^2 - 4(2)(-5)}}{2(2)} = \frac{-3 \pm \sqrt{49}}{4} = \frac{-3 \pm 7}{4}$$

So $x = \frac{-3+7}{4} = \frac{4}{4} = 1$ or $x = \frac{-3-7}{4} = \frac{-10}{4} = -\frac{5}{2}$.

Example 5 Solve the quadratic equation for x : $x^2 + 3x - 5 = 0$.

Solution
$$x = \frac{-b \pm \sqrt{b^2 - 4ac}}{2a} = \frac{-3 \pm \sqrt{(3)^2 - 4(1)(-5)}}{2(1)} = \frac{-3 \pm \sqrt{29}}{2}$$

So $x = \frac{-3+\sqrt{29}}{2} \approx 1.19$ or $x = \frac{-3-\sqrt{29}}{2} \approx 4.19$.

Example 6 Solve the quadratic equation for x : $x^2 - x + 1 = 0$.

Solution
$$x = \frac{-b \pm \sqrt{b^2 - 4ac}}{2a} = \frac{-(-2) \pm \sqrt{(-2)^2 - 4(2)(1)}}{2(2)} = \frac{2 \pm \sqrt{-4}}{4} = \frac{2 \pm 2i}{4} = \frac{1 \pm i}{2}$$

So $x = \frac{1+i}{2}$ or $x = \frac{1-i}{2}$.

Example 7 The sum of three times x and twice the square of x is equal to seven. Solve the quadratic equation for x .

Solution $2x^2 + 3x = 7$ so $2x^2 + 3x - 7 = 0$.

$$x = \frac{-b \pm \sqrt{b^2 - 4ac}}{2a} = \frac{-3 \pm \sqrt{(3)^2 - 4(2)(-7)}}{2(2)} = \frac{-3 \pm \sqrt{51}}{4}$$

So $x = \frac{-3+\sqrt{51}}{4}$ or $x = \frac{-3-\sqrt{51}}{4}$.

Solve each quadratic equation by factoring.

1. $y^2 - 17y + 70 = 0$ 2. $x^2 + 9x + 13 = -7$ 3. $x(x+1) = 112 - 5x$
 4. $a^2 + 25 = 10a$ 5. $2d^2 + 5d = 12$ 6. $a^2 + 3a + 2 = -3(a+2)$
 7. $10 - 9y = -2y^2$ 8. $2x^2 = 5x - 2$ 9. $c(c+4) = 3 + 3(9+c)$
 10. $a^2 = 4(2a-3)$ 11. $b(b+3) = -2$ 12. $2a(a+6) = 5 - a(a+2)$
 13. $(x+3)^2 = 6(x+15)$ 14. $10(10+y^2) - 9(y^2+2) - 2(1+y^2) = -1$

Solve each quadratic equation using the quadratic formula.

15. $2x^2 + 7x - 15 = 0$ 16. $3x^2 - x - 14 = 0$ 17. $t^2 + 4t + 2 = 0$
 18. $w^2 + 2w + 4 = 0$ 19. $2w^2 + w - 2 = 0$ 20. $3k^2 + 5k + 1 = 0$
 21. $x^2 - 4x + 4 = 0$ 22. $9x^2 + 6x + 1 = 0$ 23. $4x^2 - 12x = 0$
 24. $x^2 + 4 = 0$ 25. $-x^2 = 5x + 20$ 26. $(2x+1)(x+1) = 7$
 27. $x^2 = 1 + x$ 28. $\frac{1}{2}x^2 + \frac{1}{6}x - 1 = 0$ 29. $0.5t^2 = t + 0.5$

Solve each quadratic equation using any method.

30. $9x^2 + 12x + 4 = 0$ 31. $9x^2 + 1 = 0$ 32. $x^2 + 5x + 1 = 0$
 33. $3x^2 - 16x + 5 = 0$ 34. $x^2 = 5(x-1)$ 35. $x - \frac{1}{x} = 4 - \frac{x}{2} + \frac{1}{2x}$
 36. $\frac{x^2}{4} + 2 = \frac{3x}{2}$ 37. $x^2 - 14x + 45 = 0$ 38. $-3x^2 + 5x + 12 = 0$
 39. $9(x-1)^2 - 1 = 0$ 40. $1.9x = 4.3x^2 - 9$ 41. $\frac{x-4}{2} + \frac{x^2+x}{3} = 0$
 42. $3x^2 + 7x - 26 = 0$ 43. $x^2 + \frac{7}{6}x = \frac{1}{2}$ 44. $(x-3)(x+2) = 14$
 45. $x = 3 + \frac{4x-12}{x}$ 46. $5x^2 + 15x = 0$ 47. $(x-2)(x+4) + 16 = 4x^2$
 48. $4x^2 - 49 = 0$ 49. $2x^2 + 5x - 3 = 0$ 50. $\frac{x+3}{x} - \frac{x}{x+2} = 8$

1. $\{7, 10\}$ 2. $\{-5, -4\}$ 3. $\{-14, 8\}$ 4. $\{5\}$
5. $\left\{-4, \frac{3}{2}\right\}$ 6. $\{-4, -2\}$ 7. $\left\{2, \frac{5}{2}\right\}$ 8. $\left\{\frac{1}{2}, 2\right\}$
9. $\{-6, 5\}$ 10. $\{2, 6\}$ 11. $\{-2, -1\}$ 12. $\left\{-5, \frac{1}{3}\right\}$
13. $\{-9, 9\}$ 14. $\{-9, 9\}$ 15. $\left\{-5, \frac{3}{2}\right\}$ 16. $\left\{-2, \frac{7}{3}\right\}$
17. $\{-2 \pm \sqrt{2}\}$ 18. $\{-1 \pm i\sqrt{3}\}$ 19. $\left\{\frac{-1 \pm \sqrt{17}}{4}\right\}$ 20. $\left\{\frac{-5 \pm \sqrt{13}}{6}\right\}$
21. $\{2\}$ 22. $\left\{-\frac{1}{3}\right\}$ 23. $\{0, 3\}$ 24. $\{\pm 2i\}$
25. $\left\{\frac{-5 \pm i\sqrt{55}}{2}\right\}$ 26. $\left\{\frac{-3 \pm \sqrt{57}}{4}\right\}$ 27. $\left\{\frac{1 \pm \sqrt{5}}{2}\right\}$
28. $\left\{\frac{-1 \pm \sqrt{73}}{6}\right\}$ 29. $\{1 \pm \sqrt{2}\}$ 30. $\left\{-\frac{2}{3}\right\}$
31. $\left\{\pm \frac{i}{3}\right\}$ 32. $\left\{\frac{-6 \pm \sqrt{21}}{2}\right\}$ 33. $\left\{\frac{1}{3}, 5\right\}$
34. $\left\{\frac{5 \pm \sqrt{5}}{2}\right\}$ 35. $\left\{-\frac{1}{3}, 3\right\}$ 36. $\{2, 4\}$
37. $\{5, 9\}$ 38. $\left\{-\frac{4}{3}, 3\right\}$ 39. $\left\{\frac{2}{3}, \frac{4}{3}\right\}$
40. $\left\{\frac{19 \pm \sqrt{15,841}}{86}\right\}$ 41. $\left\{-4, \frac{3}{2}\right\}$ 42. $\left\{2, -\frac{13}{3}\right\}$
43. $\left\{\frac{1}{3}, -\frac{3}{2}\right\}$ 44. $\{-4, 5\}$ 45. $\{3, 4\}$
46. $\{-3, 0\}$ 47. $\left\{-\frac{4}{3}, 2\right\}$ 48. $\left\{\pm \frac{7}{2}\right\}$
49. $\left\{-3, \frac{1}{2}\right\}$ 50. $\left\{\frac{-11 \pm \sqrt{313}}{16}\right\}$

§3-3**ABSOLUTE VALUE EQUATIONS****Theorem**

If $|u| = c$ where u is a variable expression and c is a non-negative real number, then $u = c$ or $u = -c$.

Example 1 Solve the equation for x : $|x| = 6$.

Solution $x = 6$ or $x = -6$

Example 2 Solve the equation for x : $|x + 3| = 5$.

Solution $x + 3 = 5$ or $x + 3 = -5$
 $x = 2$ $x = -8$

Example 3 Solve the equation for y : $|2y - 4| = 7$.

Solution $2y - 4 = 7$ or $2y - 4 = -7$
 $2y = 11$ $2y = -3$
 $y = \frac{11}{2}$ $y = -\frac{3}{2}$

Example 4 Solve the equation for x : $|3x + 2| - 13 = 7$.

Solution $|3x + 2| - 13 = 7$
 $|3x + 2| = 20$
 $3x + 2 = 20$ or $3x + 2 = -20$
 $3x = 18$ $3x = -22$
 $x = 6$ $x = -\frac{22}{3}$

Example 5 Solve the equation for t : $|t^2 + 2| = 7$.

Solution $t^2 + 2 = 7$ or $t^2 + 2 = -7$
 $t^2 = 5$ $t^2 = -9$
 $\sqrt{t^2} = \pm\sqrt{5}$ $\sqrt{t^2} = \pm\sqrt{-9}$
 $t = \pm\sqrt{5}$ $t = \pm 3i$

So $t = \pm\sqrt{5}$ are the only real solutions.

Solve each equation. If there is no solution then write *no solution*.

- | | | |
|--|---|--|
| 1. $ x = 5$ | 2. $ x = 0$ | 3. $ 3v = \frac{5}{2}$ |
| 4. $ x + 3 = 5$ | 5. $ p - \frac{1}{2} = \frac{1}{4}$ | 6. $ x = -2$ |
| 7. $3 t = 12$ | 8. $ 3t = 12$ | 9. $\left \frac{y}{3}\right = 5$ |
| 10. $\frac{1}{3} w = 4$ | 11. $ x - 4 = 2$ | 12. $ 5x + 1 = 10$ |
| 13. $ 3a - a = 3$ | 14. $\frac{1}{2} 2x + 1 = 15$ | 15. $ -2x + 1 = 8$ |
| 16. $ 7z + 1 = 2$ | 17. $4 3a - 1 - 4 = -3$ | 18. $\left \frac{2}{3}x + 4\right = 16$ |
| 19. $ 1 + 3q = \frac{1}{5}$ | 20. $ 3x + 1 + 6 = 10$ | 21. $ 3x - 1 = 4$ |
| 22. $ 3x + 2 - 4 = 4$ | 23. $5 4x - 3 + 7 = 52$ | 24. $\left \frac{1}{2}t\right = 4$ |
| 25. $ 3n + 4 = \frac{1}{2}$ | 26. $ 4x^2 - 9 = 0$ | 27. $ y - 5 = 3$ |
| 28. $ -6y - 3 = 4$ | 29. $\left \frac{3x - 2}{5}\right = 1$ | 30. $ x^2 - 2 = 5x$ |
| 31. $ 3t - 1 = t - 4 $ | 32. $\left \frac{4}{5}r + 9\right = \frac{1}{3}$ | 33. $3 h - 14 - 7 = 2$ |
| 34. $-2\left \frac{4s - 3}{5}\right = -1$ | 37. $ y - 3 = 5$ | 36. $2 x + 2 = 4$ |
| 37. $ 2p = p - 4 $ | 38. $\left 4 - \frac{b}{2}\right = 3$ | 39. $ 2x + 3 = 11$ |
| 40. $2 - t - 5 = 4$ | 41. $8 - 1 - 3s = -1$ | 42. $\frac{1}{3} 3a - 7 + 8 = 10$ |

Solve for x .

- | | | |
|--------------------|--------------------|--------------------|
| 43. $ ax + b = y$ | 44. $a x + b = y$ | 45. $ 3x + y = 4$ |
|--------------------|--------------------|--------------------|

- | | | |
|--|---|--|
| 1. $\{-5, 5\}$ | 2. $\{0\}$ | 3. $\left\{-\frac{5}{6}, \frac{5}{6}\right\}$ |
| 4. $\{-2, 2\}$ | 5. $\left\{-\frac{3}{4}, \frac{3}{4}\right\}$ | 6. no solution |
| 7. $\{-4, 4\}$ | 8. $\{-4, 4\}$ | 9. $\{-15, 15\}$ |
| 10. $\{-12, 12\}$ | 11. $\{2, 6\}$ | 12. $\left\{-\frac{11}{5}, \frac{9}{5}\right\}$ |
| 13. $\left\{-\frac{3}{2}, \frac{3}{2}\right\}$ | 14. $\left\{-\frac{31}{2}, \frac{29}{2}\right\}$ | 15. $\left\{-\frac{7}{2}, \frac{9}{2}\right\}$ |
| 16. $\left\{-\frac{3}{7}, \frac{1}{7}\right\}$ | 17. $\left\{\frac{1}{4}, \frac{5}{12}\right\}$ | 18. $\{-30, 18\}$ |
| 19. $\left\{-\frac{4}{15}, -\frac{2}{5}\right\}$ | 20. $\left\{-\frac{5}{3}, 1\right\}$ | 21. $\left\{-1, \frac{5}{3}\right\}$ |
| 22. $\left\{-\frac{10}{3}, 2\right\}$ | 23. $\left\{-\frac{3}{2}, 3\right\}$ | 24. $\{-8, 8\}$ |
| 25. $\left\{-\frac{7}{6}, -\frac{3}{2}\right\}$ | 26. $\left\{\pm\frac{3}{2}\right\}$ | 27. $\{2, 8\}$ |
| 28. $\left\{-\frac{7}{6}, \frac{1}{6}\right\}$ | 29. $\left\{-1, \frac{7}{3}\right\}$ | 30. $\left\{\frac{5\pm\sqrt{33}}{2}, \frac{-5\pm\sqrt{33}}{2}\right\}$ |
| 31. $\left\{-\frac{3}{2}, \frac{5}{4}\right\}$ | 32. $\left\{-\frac{65}{6}, -\frac{35}{3}\right\}$ | 33. $\{11, 17\}$ |
| 34. $\left\{\frac{1}{8}, \frac{11}{8}\right\}$ | 37. $\{-2, 8\}$ | 36. $\{-4, 0\}$ |
| 37. $\left\{-4, \frac{4}{3}\right\}$ | 38. $\{2, 14\}$ | 39. $\{-7, 4\}$ |
| 40. no solution | 41. $\left\{-\frac{8}{3}, \frac{10}{3}\right\}$ | 42. $\left\{\frac{1}{3}, \frac{13}{3}\right\}$ |
| 43. $\left\{-\frac{y+b}{a}, \frac{y-b}{a}\right\}$ | 44. $\left\{\pm\frac{y-b}{a}\right\}$ | 45. $\left\{-\frac{4+y}{3}, \frac{4-y}{3}\right\}$ |

§3-4**RATIONAL EQUATIONS****Definition**

Rational equations are equations involving rational expressions.

The technique for solving rational equations is called clearing the fractions.

Procedure**Clearing the Fractions**

1. Factor all polynomial expressions.
2. Multiply through by the common denominator of all the terms.
3. Reduce wherever possible
4. Solve the resulting equation
5. Check your answers using the original equation

Example 1

Solve $\frac{2}{x+1} - \frac{1}{x^2+x} = \frac{3}{x}$

Solution

$$\frac{2}{x+1} - \frac{1}{x^2+x} = \frac{3}{x}$$

Step 1

$$\frac{2}{x+1} - \frac{1}{x(x+1)} = \frac{3}{x}$$

Step 2 $x(x+1)\left(\frac{2}{x+1}\right) - x(x+1)\left(\frac{1}{x(x+1)}\right) = x(x+1)\left(\frac{3}{x}\right)$

Step 3

$$2x - 1 = 3(x + 1)$$

Step 4

$$\begin{aligned} 2x - 1 &= 3x + 3 \\ 2x - 3x &= 3 + 1 \\ -x &= 4 \\ x &= -4 \end{aligned}$$

Step 5

$$\begin{aligned} \frac{2}{x+1} - \frac{1}{x^2+x} &? \frac{3}{x} \\ \frac{2}{(-4)+1} - \frac{1}{(-4)^2+(-4)} &? \frac{3}{(-4)} \\ -\frac{2}{3} - \frac{1}{12} &? -\frac{3}{4} \\ -\frac{8}{12} - \frac{1}{12} &? -\frac{3}{4} \\ -\frac{9}{12} &? -\frac{3}{4} \\ -\frac{3}{4} &= -\frac{3}{4} \end{aligned}$$

So -4 is the solution of $\frac{2}{x+1} - \frac{1}{x^2+x} = \frac{3}{x}$.

Example 2 Solve $\frac{x}{5x+5} = \frac{1}{x+2} + \frac{1}{x^2+3x+2}$.

Solution

$$\frac{x}{5x+5} = \frac{1}{x+2} + \frac{1}{x^2+3x+2}$$

$$\frac{x}{5(x+1)} = \frac{1}{x+2} + \frac{1}{(x+1)(x+2)}$$

$$5(x+1)(x+2)\left(\frac{x}{5(x+1)}\right) = 5(x+1)(x+2)\left(\frac{1}{x+2}\right) + 5(x+1)(x+2)\left(\frac{1}{(x+1)(x+2)}\right)$$

$$x(x+2) = 5(x+1) + 5$$

$$x^2 + 2x = 5x + 5 + 5$$

$$x^2 + 2x = 5x + 10$$

$$x^2 - 3x - 10 = 0$$

$$(x+2)(x-5) = 0$$

$$x+2=0 \text{ or } x-5=0$$

$$x=-2 \quad x=5$$

$$\frac{x}{5x+5} \stackrel{?}{=} \frac{1}{x+2} + \frac{1}{x^2+3x+2}$$

$$\frac{(-2)}{5(-2)+5} \stackrel{?}{=} \frac{1}{(-2)+2} + \frac{1}{(-2)^2+3(-2)+2}$$

$$\frac{2}{5} \stackrel{?}{=} \frac{1}{0} + \frac{1}{0}$$

$$\frac{2}{5} \neq \text{undefined}$$

So -2 is not a solution of $\frac{x}{5x+5} = \frac{1}{x+2} + \frac{1}{x^2+3x+2}$.

$$\frac{x}{5x+5} \stackrel{?}{=} \frac{1}{x+2} + \frac{1}{x^2+3x+2}$$

$$\frac{(5)}{5(5)+5} \stackrel{?}{=} \frac{1}{(5)+2} + \frac{1}{(5)^2+3(5)+2}$$

$$\frac{5}{30} \stackrel{?}{=} \frac{1}{7} + \frac{1}{42}$$

$$\frac{1}{6} \stackrel{?}{=} \frac{6}{42} + \frac{1}{42}$$

$$\frac{1}{6} \stackrel{?}{=} \frac{7}{42}$$

$$\frac{1}{6} = \frac{1}{6}$$

So 5 is the only solution of $\frac{x}{5x+5} = \frac{1}{x+2} + \frac{1}{x^2+3x+2}$.

Solve each equation for x .

1. $a + b = \frac{c + a}{x}$

2. $\frac{1}{a} - \frac{2}{x} = \frac{3}{b}$

3. $\frac{a}{x} + 1 = \frac{2}{x}$

4. $\frac{1}{a} + \frac{1}{b} = \frac{c}{x}$

Solve each rational equation. If there is no solution then write *no solution*.

5. $\frac{x+1}{5} = \frac{x+3}{3}$

6. $a + \frac{25}{a} = 10$

7. $\frac{4}{b-4} - \frac{3}{b-3} = 1$

8. $\frac{1}{t^2} - 16 = 0$

9. $\frac{1}{x-3} = \frac{8}{x^2-9}$

10. $\frac{5}{x-2} - \frac{2}{x+2} = \frac{3}{x^2-4}$

11. $\frac{3}{y} = 2 + \frac{1}{y}$

12. $\frac{5}{x^2-7x+12} = \frac{2}{x-3} + \frac{5}{x-4}$

13. $\frac{4}{y-4} - \frac{3}{y-3} = 1$

14. $\frac{3}{2} - \frac{z}{5} = \frac{1}{10} + \frac{3z}{20}$

15. $1 - \frac{3}{b} = \frac{10}{b^2}$

16. $\frac{3}{x^2-16} + \frac{1}{2x+8} = 0$

17. $\frac{x+2}{x^2-4} = \frac{3}{x-6}$

18. $\frac{x}{x-4} + \frac{6}{x-3} = \frac{16}{(x-4)(x-3)}$

19. $\frac{8}{a^2} + 1 = \frac{9}{a}$

20. $\frac{2}{x+2} + \frac{1}{x-2} = \frac{3}{x}$

21. $x - \frac{12}{x} = 1$

22. $5 - \frac{2}{2x-2} = \frac{3}{x^2-4}$

23. $\frac{3}{x+2} = \frac{4}{x-1}$

24. $\frac{x}{x^2-1} + \frac{2}{x+1} = \frac{1}{2x-2}$

25. $\frac{2}{p} = 3 + \frac{1}{p}$

26. $\frac{2}{4t^2-9} + \frac{1}{2t-3} = \frac{3}{2t+3}$

27. $\frac{1}{x-2} + \frac{2}{x(x-1)} + \frac{2}{x(x-1)(x-2)} = 0$

- | | | | | | | | |
|-----|------------------------------|-----|--------------------|-----|-------------|-----|--------------------|
| 1. | $\frac{a+c}{a+b}$ | 2. | $\frac{2ab}{b-3a}$ | 3. | $2-a$ | 4. | $\frac{2ab}{b-3a}$ |
| 5. | $\{-6\}$ | 6. | 5 | 7. | $\{2, 6\}$ | 8. | $\pm\frac{1}{4}$ |
| 9. | $\{5\}$ | 10. | $-\frac{11}{3}$ | 11. | $\{1\}$ | 12. | no solution |
| 13. | $\{2, 6\}$ | 14. | 4 | 15. | $\{-2, 5\}$ | 16. | -2 |
| 17. | $\{0\}$ | 18. | $\{-8, 5\}$ | 19. | $\{8, 1\}$ | 20. | 6 |
| 21. | $\{-3, 4\}$ | 22. | SKIP | 23. | $\{-11\}$ | 24. | no solution |
| 25. | $\left\{\frac{1}{3}\right\}$ | 26. | $\frac{7}{2}$ | 27. | $\{-2\}$ | | |

§4-1**LINEAR INEQUALITIES****Definition**

Linear inequalities in one variable are inequalities which can be written in one of the following forms: $ax + b > 0$
 $ax + b < 0$
 $ax + b \geq 0$
 $ax + b \leq 0$ where a and b are real numbers.

Properties**The Addition Properties of Inequalities**

If $a > b$ and c is a real number then $a + c > b + c$.

If $a < b$ and c is a real number then $a + c < b + c$.

Properties**The Multiplication Properties of Inequalities**

If $a > b$ and c is a positive real number then $ac > bc$.

If $a < b$ and c is a positive real number then $ac < bc$.

If $a > b$ and c is a negative real number then $ac < bc$.

If $a < b$ and c is a negative real number then $ac > bc$.

Example 1

Solve the inequality, $5x + 15 > 0$.

Solution

$$\begin{aligned} 5x + 15 &> 0 \\ 5x + 15 - 15 &> 0 - 15 \\ 5x &> -15 \\ \frac{5x}{5} &> \frac{-15}{5} \\ x &> -3 \end{aligned}$$

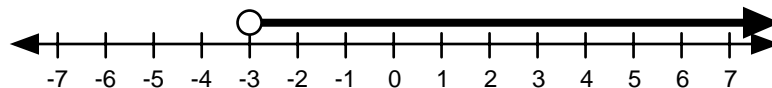
**Example 2**

Solve the inequality, $4x + 5 \leq 6$.

Solution

$$\begin{aligned} 4x + 5 &\leq 6 \\ 4x + 5 - 6 &\leq 6 - 6 \\ 4x &\leq 1 \\ \frac{4x}{4} &\leq \frac{1}{4} \\ x &\leq \frac{1}{4} \end{aligned}$$

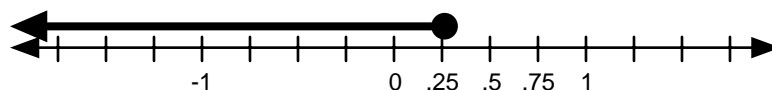

Example 3 Solve the inequality, $-2x - 4 < 0$.

Solution

$$\begin{aligned} -2x - 4 &< 0 \\ -2x - 4 + 4 &< 0 + 4 \\ -2x &< 4 \\ \frac{-2x}{-2} &> \frac{4}{-2} \\ x &> -2 \end{aligned}$$

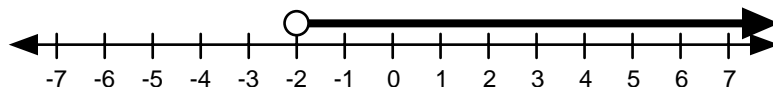

Example 4 Solve the inequality, $-16x + 7 \leq 2x - 2$.

Solution

$$\begin{aligned} -16x + 7 &\leq 2x - 2 \\ -16x + 7 - 7 &\leq 2x - 2 - 7 \\ -16x &\leq 2x - 9 \\ -16x - 2x &\leq 2x - 9 - 2x \\ -18x &\leq -9 \\ \frac{-18x}{-18} &\geq \frac{-9}{-18} \\ x &\geq \frac{1}{2} \end{aligned}$$

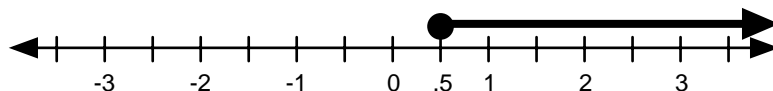

Example 5 Solve the inequality, $(x - 3)^2 \geq x^2 + 3$.

Solution

$$\begin{aligned} (x - 3)^2 &\geq x^2 + 3 \\ x^2 - 6x + 9 &\geq x^2 + 3 \\ x^2 - 6x + 9 - x^2 &\geq x^2 + 3 - x^2 \\ -6x + 9 &\geq 3 \\ -6x + 9 - 9 &\geq 3 - 9 \\ -6x &\geq -6 \\ \frac{-6x}{-6} &\leq \frac{-6}{-6} \\ x &\leq 1 \end{aligned}$$

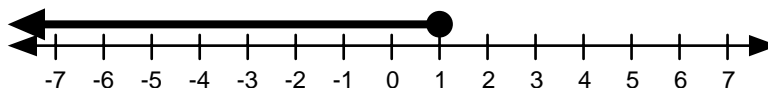

Solve each linear inequality and graph the solution on a number line.

1. $3x > 36$

2. $x + 14 < 64$

3. $x - 7 \geq 43$

4. $\frac{x}{4} \leq 8$

5. $3y - 2 < -14$

6. $-2x > 14$

7. $2r + 1 \leq 4r - 5$

8. $\frac{2x}{3} \geq 6$

9. $-2(x - 3) > 8$

10. $1 - 2t < 7$

11. $2(m - 5) \geq -9$

12. $\frac{x}{9} - 5 \leq 40$

13. $\frac{5x}{3} < 10$

14. $13x + 57 > 182$

15. $14 \leq 3x - 4$

16. $5(b - 3) \geq 7$

17. $\frac{x}{3} + 1 > 22$

18. $12x - 3 < 8x - 9$

19. $-3k \geq -2$

20. $2x + 1 \leq 5$

21. $\frac{7 - 2s}{3} < 2$

22. $6s + 8 > 8 - 5s$

23. $\frac{2 + 9x}{6} \leq 12$

24. $6s + 3 \geq 4s - 1$

25. $4 + 6(r + 2) > 9$

26. $7 - 2x < 1$

27. $\frac{3t}{2} - 10 \geq 6$

28. $0.3c + 1.5 \leq 0.8c$

29. $0.1(v - 8) < 10$

30. $\frac{3w}{2} - \frac{5}{6} > \frac{w}{3}$

31. $41.7x - 13.2 \leq 91.8$

32. $\frac{2}{3}t + 8 \geq \frac{5}{4}t$

33. $6(k + 10) > 5(k + 14)$

34. $3t - 7 < 8t + 5$

35. $1.83 \geq 7x - 4.19$

36. $r + \frac{1}{3} \leq \frac{2}{3}r + \frac{5}{6}$

37. $3s + 1 < 7s - 15$

38. $\frac{3y}{4} + 7 > 10$

39. $2 - 2(7 - 2x) \leq 3(3 - x)$

40. $8 - 9a \geq 9a - 8$

41. $\frac{3}{5}(2t - 4) > \frac{1}{5}t$

42. $4(1 - b) < 2(b + 14)$

43. $\frac{5x}{2} + 2 \geq 3x - 1$

44. $3a + 2 \leq \frac{a}{5} - 4$

45. $5 - x < \frac{2x}{3} - 6$

46. $\frac{x}{2} - \frac{2}{3} > \frac{1}{4}$

47. $\frac{2x}{3} - \frac{1}{2} \leq \frac{1}{4}$

48. $\frac{2x}{3} - 2 \geq \frac{1}{5}$

49. $3 + 2(x + 5) > x + 5(x + 1) + 1$

50. $3 - 5t < 18$

- | | | | |
|------------------------|--------------------------|------------------------------|----------------------------|
| 1. $x > 126$ | 2. $x < 50$ | 3. $x \geq 50$ | 4. $x \leq 32$ |
| 5. $y < -4$ | 6. $x < -7$ | 7. $r \geq 3$ | 8. $x \geq 9$ |
| 9. $x < -1$ | 10. $t > -3$ | 11. $m \geq \frac{1}{2}$ | 12. $x \leq 405$ |
| 13. $x < 6$ | 14. $x > \frac{125}{13}$ | 15. $x \geq 6$ | 16. $b \geq \frac{22}{5}$ |
| 17. $x > 63$ | 18. $x < -\frac{3}{2}$ | 19. $k \leq \frac{2}{3}$ | 20. $x \leq 2$ |
| 21. $x > \frac{1}{2}$ | 22. $s > 0$ | 23. $x \leq \frac{70}{9}$ | 24. $s \geq -2$ |
| 25. $r > -\frac{7}{6}$ | 26. $x > 3$ | 27. $t \geq \frac{32}{3}$ | 28. $c \geq 3$ |
| 29. $v < 9$ | 30. $w \geq \frac{5}{7}$ | 31. $x \leq \frac{350}{139}$ | 32. $t \leq \frac{96}{7}$ |
| 33. $k > 10$ | 34. $t > -\frac{12}{5}$ | 35. $x \leq -\frac{43}{50}$ | 36. $r \leq \frac{3}{2}$ |
| 37. $s > 4$ | 38. $y > 4$ | 39. $x \leq 3$ | 40. $a \leq \frac{9}{8}$ |
| 41. $t > \frac{12}{5}$ | 42. $b > -4$ | 43. $x \leq 6$ | 44. $a \leq -\frac{15}{7}$ |
| 45. $x > \frac{33}{5}$ | 46. $x > \frac{11}{6}$ | 47. $x \leq \frac{9}{8}$ | 48. $x \geq \frac{33}{10}$ |
| 49. $x < \frac{7}{4}$ | 50. $t > -3$ | | |

§4-2

QUADRATIC INEQUALITIES

Definition

Quadratic inequalities in one variable are inequalities which can be written in one of the following forms: $ax^2 + bx + c > 0$,

$$ax^2 + bx + c < 0,$$

$$ax^2 + bx + c \geq 0 \text{ or}$$

$$ax^2 + bx + c \leq 0 \text{ where } a, b \text{ and } c \text{ are real numbers.}$$

Procedure

Solving Quadratic Inequalities

1. Move all terms to one side.
2. Simplify and factor the quadratic expression.
3. Find the roots of the corresponding quadratic equation.
4. Use the roots to divide the number line into regions.
5. Test each region using the inequality.

Example 1

Solve the inequality, $x^2 > x + 2$.

Solution

$$\begin{aligned} x^2 &> x + 2 \\ x^2 - x - 2 &> 0 \\ (x - 2)(x + 1) &> 0 \end{aligned}$$

The corresponding equation is $(x - 2)(x + 1) = 0$ so...

$$\begin{array}{l} x - 2 = 0 \quad \text{or} \quad x + 1 = 0 \\ x = 2 \quad \quad \quad x = -1 \end{array}$$

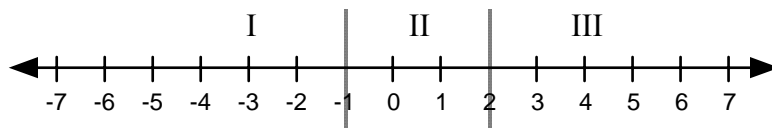

Now we test one point in each region.

Region	Test Point	Inequality	Status
I	$x = -2$	$(x - 2)(x + 1) = (-2 - 2)(-2 + 1) = 4 > 0$	True
II	$x = 0$	$(x - 2)(x + 1) = (0 - 2)(0 + 1) = -2 > 0$	False
III	$x = 3$	$(x - 2)(x + 1) = (3 - 2)(3 + 1) = 4 > 0$	True

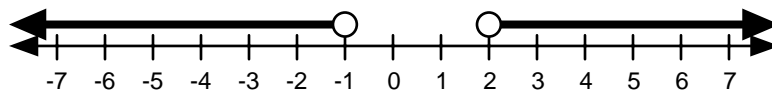

So the solution to this inequality is $x < -1$ or $x > 2$.

Example 2 Solve the inequality, $(x + 3)^2 \geq 2(x^2 + 7)$.

Solution

$$\begin{aligned} (x + 3)^2 &\geq 2(x^2 + 7) \\ x^2 + 6x + 9 &\geq 2x^2 + 14 \\ -x^2 + 6x - 5 &\geq 0 \\ -(x^2 - 6x + 5) &\geq 0 \end{aligned}$$

$$\frac{-(x^2 - 6x + 5)}{-1} \leq \frac{0}{-1}$$

$$\begin{aligned} x^2 - 6x + 5 &\leq 0 \\ (x - 1)(x - 5) &\leq 0 \end{aligned}$$

The corresponding equation is $(x - 1)(x - 5) = 0$ so...

$$\begin{aligned} x - 1 = 0 &\quad \text{or} \quad x - 5 = 0 \\ x = 1 &\quad \quad \quad x = 5 \end{aligned}$$

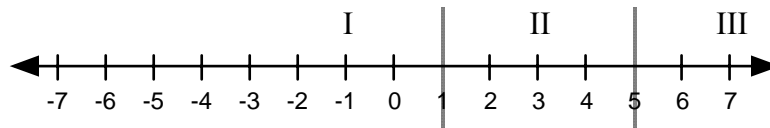

Now we check one point in each region.

Region	Test Point	Inequality	Status
I	$x = 0$	$(x - 1)(x - 5) = (0 - 1)(0 - 5) = 5 < 0$	False
II	$x = 2$	$(x - 1)(x - 5) = (2 - 1)(2 - 5) = -3 < 0$	True
III	$x = 6$	$(x - 1)(x - 5) = (6 - 1)(6 - 5) = 5 < 0$	False

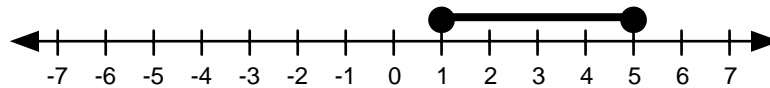

So the solution to this inequality is $1 \leq x \leq 5$.

Solve each quadratic inequality, and graph the solution on a number line.

1. $y^2 - 17y + 70 < 0$

2. $x^2 + 9x + 13 > -7$

3. $x(x+1) > 112 - 5x$

4. $a^2 + 3a + 2 < -3(a+2)$

5. $2x^2 \leq 5x - 2$

6. $10 - 9y \geq -2y^2$

7. $b(b+3) \geq -2$

8. $a^2 \leq 4(2a-3)$

9. $y^2 - 17y + 70 < 0$

10. $x^2 + 9x + 13 > -7$

11. $x(x+1) > 112 - 5x$

12. $a^2 + 25 < 10a$

13. $2d^2 + 5d \leq 12$

14. $a^2 + 3a + 2 \geq -3(a+2)$

15. $10 - 9y \geq -2y^2$

16. $2x^2 \leq 5x - 2$

17. $c(c+4) < 3 + 3(9+c)$

18. $2a(a+6) > 5 - a(a+2)$

19. $b(b+3) > -2$

20. $a^2 < 4(2a-3)$

21. $(x+3)^2 \leq 6(x+15)$

22. $2x^2 + 7 \geq 9x$

23. $7x^2 \geq 4(1+3x)$

24. $3x^2 + 7x \leq -2$

25. $-8 < 4(x - x^2)$

26. $x^2 - x - 2 > 0$

27. $2k^2 + 3k - 2 > 0$

28. $t^2 + 2t - 3 < 0$

29. $4x^2 + 8 \leq 33x$

30. $x^2 \geq 4(x-5)$

31. $x^2 + 4 \geq 2x^2 - 3x$

32. $10 - 3x \leq x^2$

33. $4 < 13x - 3x^2$

34. $6(x^2 + 1) > -13$

35. $6x - x^2 > 8$

36. $20a^2 < 1 - a$

37. $8x \leq -3(1 - x^2)$

38. $y^2 \geq 25$

39. $t^2 + 18 \geq 11t$

40. $3x(x+1) \leq x(x+5)$

41. $x^2 < 8$

42. $x^2 + 3x > 12$

43. $2t^2 > 9t + 18$

44. $4x^2 - 9x + 2 < 0$

- | | | |
|--|---|--|
| 1. $7 < y < 10$ | 2. $x < -5$ or $x > -4$ | 3. $x < -14$ or $x > 8$ |
| 4. $-4 < a < -2$ | 5. $\frac{1}{2} \leq x \leq 2$ | 6. $y \leq 2$ or $y \geq \frac{5}{2}$ |
| 7. $b \leq -2$ or $b \geq -1$ | 8. $2 \leq a \leq 6$ | 9. $7 < y < 10$ |
| 10. $x < -5$ or $x > -$ | 11. $x < -14$ or $x > 8$ | 12. no solution |
| 13. $-4 \leq d \leq \frac{3}{2}$ | 14. $x \leq -4$ or $x \geq -2$ | 15. $y \leq 2$ or $y \geq \frac{5}{2}$ |
| 16. $\frac{1}{2} \leq x \leq 2$ | 17. $-6 < c < 5$ | 18. $a < -5$ or $a > \frac{1}{3}$ |
| 19. $b \leq -2$ or $b \geq -1$ | 20. $2 < a < 6$ | 21. $-9 \leq x \leq 9$ |
| 22. $x < 1$ or $x \geq \frac{7}{2}$ | 23. $x \leq -\frac{2}{7}$ or $x \geq 2$ | 24. $-2 \leq x \leq -\frac{1}{3}$ |
| 25. $-1 < x < 2$ | 26. $x < -1$ or $x > 2$ | 27. $k < -2$ or $k > \frac{1}{2}$ |
| 28. $-3 < t < 1$ | 29. $\frac{1}{4} \leq x \leq 8$ | 30. all real numbers |
| 31. $-1 < x < 4$ | 32. $x \leq -5$ or $x \geq 2$ | 33. $\frac{1}{3} < x < 4$ |
| 34. no real solutions | 35. $2 < x < 4$ | 36. $-\frac{1}{4} < x < \frac{1}{5}$ |
| 37. $x \leq -\frac{1}{3}$ or $x \geq 3$ | 38. $x \leq -5$ or $x \geq 5$ | 39. $t \leq 2$ or $t \geq 9$ |
| 40. $0 \leq x \leq 1$ | 41. $-2\sqrt{2} < x < 2\sqrt{2}$ | |
| 42. $x < \frac{-3 - \sqrt{57}}{2}$ or $x > \frac{-3 + \sqrt{57}}{2}$ | | |
| 43. $t < -\frac{3}{2}$ or $t > 6$ | 44. $\frac{1}{4} < x < 2$ | |

§4-3**ABSOLUTE VALUE INEQUALITIES****Theorem**

If $|u| < c$ where u is a variable expression and c is non-negative, then $-c < u < c$.

Example 1 Solve the inequality, $|x| < 6$.

Solution If $|x| < 6$ then $-6 < x < 6$.

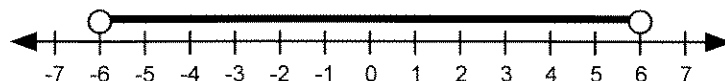

Example 2 Solve the inequality, $|x + 2| \leq 4$.

Solution If $|x + 2| \leq 4$ then $-4 \leq x + 2 \leq 4$.

$$\begin{aligned} -4 &\leq x + 2 \leq 4 \\ -4 - 2 &\leq x + 2 - 2 \leq 4 - 2 \\ -6 &\leq x \leq 2 \end{aligned}$$

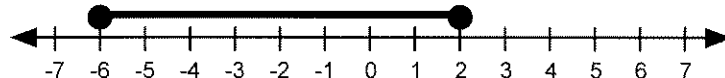

Example 3 Solve the inequality, $-3|x - 2| + 1 > -8$.

Solution

$$\begin{aligned} -3|x - 2| + 1 &> -8 \\ -3|x - 2| + 1 - 1 &> -8 - 1 \\ -3|x - 2| &> -9 \\ \frac{-3|x - 2|}{-3} &< \frac{-9}{-3} \\ |x - 2| &< 3 \end{aligned}$$

If $|x - 2| < 3$ then $-3 < x - 2 < 3$.

$$\begin{aligned} -3 &< x - 2 < 3 \\ -3 + 2 &< x - 2 + 2 < 3 + 2 \\ -1 &< x < 5 \end{aligned}$$

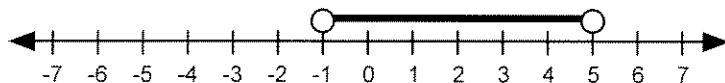

Theorem

If $|u| > c$ where u is a variable expression and c is non-negative, then $u > c$ or $u < -c$.

Example 4 Solve the inequality, $|x| > 5$.

Solution If $|x| > 5$ then $x > 5$ or $x < -5$.

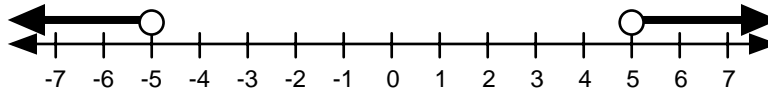

Example 5 Solve the inequality, $|x-1| \geq 5$.

Solution If $|x-1| \geq 5$ then $x-1 \geq 5$ or $x-1 \leq -5$.

$$\begin{array}{rcl} x-1 & \geq & 5 \\ x-1+1 & \geq & 5+1 \\ x & \geq & 6 \end{array} \quad \text{or} \quad \begin{array}{rcl} x-1 & \leq & -5 \\ x-1+1 & \leq & -5+1 \\ x & \leq & -4 \end{array}$$

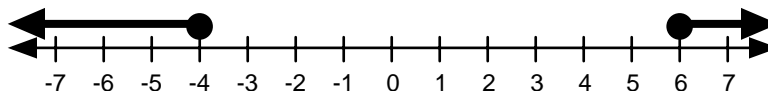

Example 6 Solve the inequality, $-2|x-1|+10 < 2$.

Solution

$$\begin{aligned} -2|x-1|+10 &< 2 \\ -2|x-1|+10-10 &< 2-10 \\ -2|x-1| &< -8 \end{aligned}$$

$$\frac{-2|x-1|}{-2} > \frac{-8}{-2}$$

$$|x-1| > 4$$

$$\begin{array}{rcl} \text{If } |x-1| > 4 \text{ then } & x-1 > 4 & \text{or} & x-1 < -4. \\ & x-1 > 4 & & x-1 < -4 \\ & x-1+1 > 4+1 & & x-1+1 < -4+1 \\ & x > 5 & & x < -3 \end{array}$$

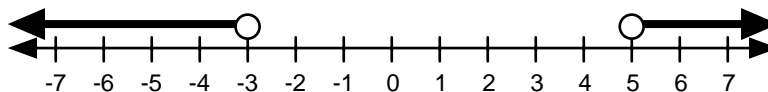

Solve each absolute value inequality, and graph the solution on a number line.

1. $|x| > 4$

2. $|x| + 2 < 5$

3. $|3v| \geq \frac{5}{2}$

4. $|x| + 3 \leq 5$

5. $\left| \frac{y}{3} \right| < 5$

6. $|y - 5| > 9$

7. $3|t| \leq 12$

8. $|3t| \geq 12$

9. $|p| - \frac{1}{2} > \frac{1}{4}$

10. $\left| 4 - \frac{b}{2} \right| < 3$

11. $|x - 4| \geq 2$

12. $|5x + 1| \leq 10$

13. $\frac{1}{3}|w| < 4$

14. $4|x| > 20$

15. $|-2x + 1| \leq 8$

16. $|3a - a| \geq 3$

17. $|4x| > 20$

18. $\frac{1}{2}|2x + 1| < 15$

19. $\frac{1}{3}|x + 2| \geq \frac{2}{3}$

20. $-|x - 3| + 5 \leq 1$

21. $2 - 3|1 - x| < -1$

22. $|7z + 1| > 2$

23. $4|3a - 1| - 4 \leq -3$

24. $\left| \frac{2}{3}x + 4 \right| \geq 16$

25. $|1 + 3q| > \frac{1}{5}$

26. $|3x + 1| + 6 < 10$

27. $|3x - 1| \geq 4$

28. $5|4x - 3| + 7 \leq 52$

29. $\frac{1}{3}|3a - 7| + 8 < 10$

30. $|2x + 9| > 11$

31. $\left| \frac{1}{2}t \right| \leq 4$

32. $5|4x - 3| + 7 \geq 52$

33. $|4x - 7| - 5 > -5$

34. $|3x + 2| - 4 < 4$

35. $|3n + 4| \geq \frac{1}{2}$

36. $5|4x - 7| - 5 \leq -5$

37. $|3x - 2| + 1 < -1$

38. $-3|2 - x| + 5 > -13$

39. $\left| \frac{3x - 2}{5} \right| \leq 1$

40. $|-6y - 3| \geq 4$

41. $\frac{1}{2}|2 - x| > 1$

42. $-11 < -1 - 3|2 - x|$

43. $|y - 9| \geq 5$

44. $\left| \frac{4}{5}r + 9 \right| \leq \frac{1}{3}$

45. $3|h - 14| - 7 > 2$

1. $x > 4$ or $x < -4$
2. $-3 < x < 3$
3. $v \geq \frac{5}{6}$ or $v \leq -\frac{5}{6}$
4. $-2 \leq x \leq 2$
5. $-15 < y < 15$
6. $y > 14$ or $y < -4$
7. $-4 \leq t \leq 4$
8. $t \geq 4$ or $t \leq -4$
9. $p > \frac{3}{4}$ or $p < -\frac{3}{4}$
10. $2 < b < 14$
11. $x \geq 6$ or $x \leq 2$
12. $-\frac{11}{5} \leq x \leq \frac{9}{5}$
13. $-12 < w < 12$
14. $x > 5$ or $x < -5$
15. $-\frac{7}{2} \leq x \leq \frac{9}{2}$
16. $a \geq \frac{3}{2}$ or $a \leq -\frac{3}{2}$
17. $x > 5$ or $x < -5$
18. $-\frac{31}{2} < x < \frac{29}{2}$
19. $x \geq 0$ or $x \leq -4$
20. $x \geq 7$ or $x \leq -1$
21. $x < 0$ or $x > 2$
22. $z > \frac{1}{7}$ or $z < -\frac{3}{7}$
23. $\frac{1}{4} \leq a \leq \frac{5}{12}$
24. $x \geq 18$ or $x \leq -30$
25. $q > -\frac{4}{15}$ or $q < -\frac{2}{5}$
26. $-\frac{5}{3} < x < 1$
27. $x \geq \frac{5}{3}$ or $x \leq -1$
28. $-\frac{3}{2} \leq x \leq 3$
29. $\frac{1}{3} < a < \frac{13}{3}$
30. $x > 1$ or $x < -10$
31. $-8 \leq t \leq 8$
32. $-\frac{3}{2} \leq x \leq 3$
33. $x > \frac{7}{4}$ or $x < \frac{7}{4}$
34. $-2 < x < \frac{10}{3}$
35. $n \geq -\frac{7}{6}$ or $n \leq -\frac{3}{2}$
36. $x = \frac{7}{4}$
37. no solution
38. $-4 < x < 8$
39. $-1 \leq x \leq \frac{7}{3}$
40. $y \leq -\frac{7}{6}$ or $y \geq \frac{1}{6}$
41. $x < 0$ or $x > 4$
42. $-\frac{4}{3} < x < \frac{10}{3}$
43. $y \geq 14$ or $y \leq 4$
44. $-\frac{35}{3} < r < -\frac{65}{6}$
45. $n > 17$ or $n < 11$

§5-1

COORDINATE GEOMETRY

Definition

A **coordinate plane** consists of a plane divided into four **quadrants** (I, II, III and IV) by two perpendicular number lines called the **x-axis** and the **y-axis**. The point where the axes intersect is called the **origin**.

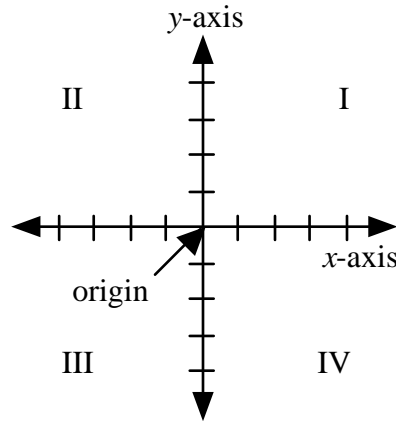

Example 1

Plot each of the following points on a coordinate plane:

A(2, 3), **B**(-4, 2), **C**(-2, -3), **D**(4, -2), **E**(0, -3), **F**(3, 0), **O**(0, 0)

Solution

Plotting the points produces the plot below.

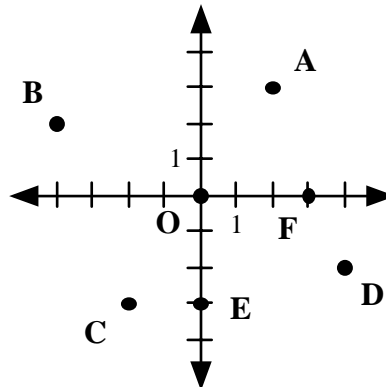

The results above illustrate the fact that the general location of a point can be determined by the signs of its coordinates. These results are summarized below.

Summary

<u>x-coordinate</u>	<u>y-coordinate</u>	<u>Location</u>
+	+	Quadrant I
-	+	Quadrant II
-	-	Quadrant III
+	-	Quadrant IV
Any	0	x-axis
0	Any	y-axis
0	0	Origin

Formula**The Midpoint Formula**

The coordinates of the midpoint between two points in a plane (x_1, y_1) and (x_2, y_2) are given by:

$$\mathbf{M}\left(\frac{x_2 + x_1}{2}, \frac{y_2 + y_1}{2}\right)$$

Formula**The Distance Formula**

The distance between two points in a plane (x_1, y_1) and (x_2, y_2) is given by:

$$d = \sqrt{(x_2 - x_1)^2 + (y_2 - y_1)^2}$$

Example 2

Consider two points **A**(5, -3) and **B**(-1, 1).

- a. Find the midpoint for these two points.
- b. Find the distance between these two points.

Solution

- a. Let point A be the first point and point B be the second point.

$$\begin{aligned} \mathbf{M}\left(\frac{x_2 + x_1}{2}, \frac{y_2 + y_1}{2}\right) &= \mathbf{M}\left(\frac{-1 + 5}{2}, \frac{1 + (-3)}{2}\right) \\ &= \mathbf{M}\left(\frac{4}{2}, \frac{-2}{2}\right) \\ &= \mathbf{M}(2, -1) \end{aligned}$$

- b. Let point A be the first point and point B be the second point.

$$\begin{aligned} d &= \sqrt{(x_2 - x_1)^2 + (y_2 - y_1)^2} \\ &= \sqrt{[(-1) - 5]^2 + [1 - (-3)]^2} \\ &= \sqrt{(-6)^2 + (4)^2} \\ &= \sqrt{36 + 16} \\ &= \sqrt{52} \\ &= \sqrt{4 \cdot 13} \\ &= 2\sqrt{13} \end{aligned}$$

In three dimensions, the midpoint formula and distance formula are slightly different.

Formula**The Midpoint Formula in Three Dimensions**

The coordinates of the midpoint between two points in space (x_1, y_1, z_1) and (x_2, y_2, z_2) are given by:

$$\mathbf{M}\left(\frac{x_2 + x_1}{2}, \frac{y_2 + y_1}{2}, \frac{z_2 + z_1}{2}\right)$$

Formula**The Distance Formula in Three Dimensions**

The distance between two points in space (x_1, y_1, z_1) and (x_2, y_2, z_2) is given by:

$$d = \sqrt{(x_2 - x_1)^2 + (y_2 - y_1)^2 + (z_2 - z_1)^2}$$

Use the diagram below to answer the questions.

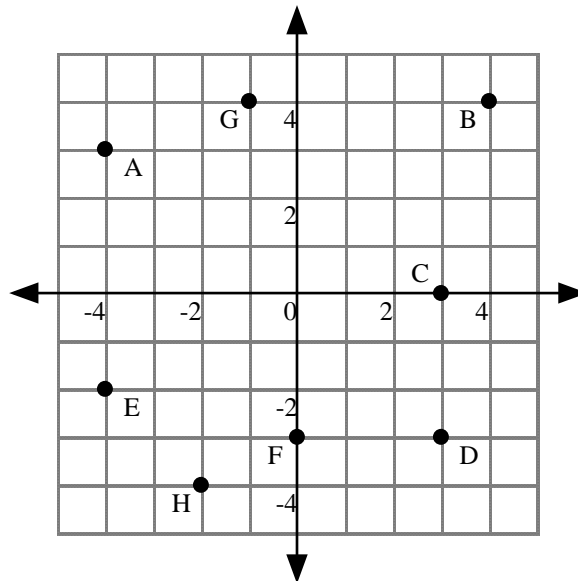

Write the coordinates for each point.

- | | | | |
|------|------|------|------|
| 1. A | 2. B | 3. C | 4. D |
| 5. E | 6. F | 7. G | 8. H |

In which quadrant or on which axis is each point?

- | | | | |
|-------|-------|----------------|-----------------|
| 9. A | 10. B | 11. C | 12. D |
| 13. E | 14. F | 15. (500, -20) | 16. (-35, -150) |

Find the midpoint of the segment joining each pair of points.

- | | | | |
|-------------------------------|------------------------------------|-------------|-------------|
| 17. E and H | 18. C and G | 19. A and C | 20. F and D |
| 21. C and D | 22. A and D | 23. A and E | 24. F and H |
| 25. (-69, 28) and (15, -7) | 26. (3, -4) and (15, 10) | | |
| 27. (6, -3, 9) and (8, 7, 13) | 28. (60, -4, -30) and (51, 1, -37) | | |

Find the distance between each pair of points. Simplify if possible.

- | | | | |
|-------------------------------|------------------------------------|-------------|-------------|
| 29. E and H | 30. C and G | 31. A and C | 32. F and D |
| 33. C and D | 34. A and D | 35. A and E | 36. F and H |
| 37. (-69, 28) and (15, -7) | 38. (3, -4) and (15, 10) | | |
| 39. (6, -3, 9) and (8, 7, 13) | 40. (60, -4, -30) and (51, 1, -37) | | |

- | | | | |
|--------------------------------------|------------------------------------|--|---|
| 1. $(-4, 3)$ | 2. $(4, 4)$ | 3. $(3, 0)$ | 4. $(3, -3)$ |
| 5. $(-4, -2)$ | 6. $(0, -3)$ | 7. $(-1, 4)$ | 8. $(-2, -4)$ |
| 9. Quadrant II | 10. Quadrant I | 11. x -axis | 12. Quadrant IV |
| 13. Quadrant III | 14. y -axis | 15. Quadrant IV | 16. Quadrant III |
| 17. $(-3, -3)$ | 18. $(1, 2)$ | 19. $\left(-\frac{1}{2}, \frac{3}{2}\right)$ | 20. $\left(\frac{3}{2}, -3\right)$ |
| 21. $\left(3, -\frac{3}{2}\right)$ | 22. $\left(-\frac{1}{2}, 0\right)$ | 23. $\left(-4, \frac{1}{2}\right)$ | 24. $\left(-1, -\frac{7}{2}\right)$ |
| 25. $\left(-27, \frac{21}{2}\right)$ | 26. $(9, 3)$ | 27. $(7, 2, 11)$ | 28. $\left(\frac{111}{2}, -\frac{3}{2}, -\frac{67}{2}\right)$ |
| 29. $2\sqrt{2}$ | 30. $4\sqrt{2}$ | 31. $\sqrt{58}$ | 32. 3 |
| 33. 3 | 34. $\sqrt{85}$ | 35. 5 | 36. $\sqrt{5}$ |
| 37. 91 | 38. $2\sqrt{85}$ | 39. $2\sqrt{30}$ | 40. $\sqrt{155}$ |

§5-2**LINEAR RELATIONS****Definition**

The **slope** of a line measures the direction that a line travels. It can be calculated using the formula $m = \frac{y_2 - y_1}{x_2 - x_1}$ where (x_1, y_1) and (x_2, y_2) are two points on the line.

Lines with positive slope increase from left to right, while lines with negative slope decrease from left to right. Horizontal lines have slope zero while the slope of vertical lines is undefined.

Definition

The **y-intercept** of a line is the y coordinate of the point where the line crosses the y-axis.

There are two primary forms in which linear relations can be expressed.

Definition

The **slope-intercept form** for the equation of a line is $y = mx + b$ where m is the slope of the line and b is the y-intercept.

Definition

The **standard form** for the equation of a line is $Ax + By = C$ where A , B and C are real numbers.

Example 1

Find the slope and y-intercept for the line $2x + 3y = 9$.

Solution

Solving for y changes the line into slope-intercept form.

$$\begin{aligned}2x + 3y &= 9 \\3y &= -2x + 9 \\y &= -\frac{2}{3}x + 3\end{aligned}$$

Thus the slope is $-\frac{2}{3}$ and the y-intercept is 3.

Example 2

Find the equation (in slope-intercept form) of the line that passes through the points $(-2, 3)$ and $(6, 7)$.

Solution

The slope of the line is $m = \frac{y_2 - y_1}{x_2 - x_1} = \frac{7 - 3}{6 - (-2)} = \frac{4}{8} = \frac{1}{2}$

So the equation becomes $y = \frac{1}{2}x + b$.

Substituting the point $(6, 7)$ into the equation produces: $7 = \frac{1}{2} \cdot 6 + b$

$$\begin{aligned}7 &= 3 + b \\7 - 3 &= 3 + b - 3 \\4 &= b\end{aligned}$$

Therefore the line has the equation: $y = \frac{1}{2}x + 4$.

Property

Two lines are **parallel** if they have the same slope. That is $m_1 = m_2$ where m_1 and m_2 are the slopes of the two lines.

Example 3

Find the equation (in slope-intercept form) of the line that is parallel to the line $y = \frac{1}{3}x - 2$ and passes through the point $(-3, 1)$.

Solution

The slope of the original line is $\frac{1}{3}$ so the slope of the new line must also be $\frac{1}{3}$.

So the equation for the new line is $y = \frac{1}{3}x + b$.

Substituting the point $(-3, 1)$ into the equation produces: $1 = \frac{1}{3} \cdot (-3) + b$

$$\begin{aligned} 1 &= -1 + b \\ 1 + 1 &= -1 + b + 1 \\ 2 &= b \end{aligned}$$

Therefore the line has the equation: $y = \frac{1}{3}x + 2$.

Property

Two lines are **perpendicular** if their slopes are negative reciprocals of each other. That is, $m_1 = -\frac{1}{m_2}$ where m_1 and m_2 are the slopes of the two lines.

Example 4

Find the equation (in slope-intercept form) of the line that is perpendicular to the line $y = \frac{1}{3}x - 2$ and passes through the point $(-3, 1)$.

Solution

The slope of the original line is $\frac{1}{3}$ so the slope of the new line must be -3 .

So the equation for the new line is $y = -3x + b$.

Substituting the point $(-3, 1)$ into the equation produces: $1 = -3 \cdot (-3) + b$

$$\begin{aligned} 1 &= 9 + b \\ 1 - 9 &= 9 + b - 9 \\ -8 &= b \end{aligned}$$

Therefore the line has the equation: $y = -3x - 8$.

Find the slope and y-intercept for each line below

- | | | |
|--------------------------------------|--------------------------------------|---------------------------------|
| 1. $4x - 2y = 5$ | 2. $y - 2x = 4$ | 3. $y = \frac{1}{4}x + 7$ |
| 4. $\frac{1}{2}y = \frac{1}{3}x + 2$ | 5. $y + 3x = -1$ | 6. $3x + 2y = 4$ |
| 7. $5x - 3y = 0$ | 8. $1 = \frac{2}{3}y + \frac{1}{5}x$ | 9. $2x + 5y = 10$ |
| 10. $2x + 3y = 6$ | 11. $y = 5$ | 12. $3x - \frac{5}{6}y + 2 = 0$ |

Write an equation in slope-intercept form for each of the following lines.

- The line with a slope of $\frac{1}{3}$ and a y-intercept of 13.
- The line with a slope of -3 and a y-intercept of 4.
- The line with a slope of 5 which passes through the point (1, 3).
- The line with a slope of -2 which passes through the point (4, -1).
- The line which passes through the points (-2, -5) and (0, 1).
- The line which passes through the points (5, -2) and (-3, 4).
- The line which is parallel to $y = -2x + 7$ and passes through the point (2, 10).
- The line which is parallel to $y = -\frac{2}{3}x + 1$ and passes through the point (2, 3).
- The line which is perpendicular to $2x - y = -3$ and passes through the point (3, 0).
- The line which is perpendicular to $y = \frac{1}{2}x - 3$ and passes through the point (1, 5).
- The line which is parallel to $y = 5$ and passes through the point (4, -2).
- The line which is perpendicular to $y = -2$ and passes through the point (-1, -3).
- The line which is perpendicular to $x = 4$ and passes through the point (-4, 1).
- The line which is parallel to $x = -1$ and passes through the point (-5, -3).
- A line segment has endpoints (-5, 4) and (13, -2). Find the equation of the line which is perpendicular to this segment and which passes through the midpoint of the line segment.

1. $m = 2; b = -\frac{5}{2}$

2. $m = 2; b = 4$

3. $m = \frac{1}{4}; b = 7$

4. $m = \frac{2}{3}; b = 4$

5. $m = -3; b = -1$

6. $m = -\frac{3}{2}; b = 2$

7. $m = \frac{5}{3}; b = 0$

8. $m = -\frac{3}{10}; b = \frac{3}{2}$

9. $m = -\frac{2}{5}; b = 2$

10. $m = -\frac{2}{3}; b = 2$

11. $m = 0; b = 5$

12. $m = \frac{18}{5}; b = \frac{12}{5}$

13. $y = \frac{1}{3}x + 13$

14. $y = -3x + 4$

15. $y = 5x - 2$

16. $y = -2x + 7$

17. $y = 3x + 1$

18. $y = -\frac{3}{4}x + \frac{7}{4}$

19. $y = -2x + 14$

20. $y = -\frac{2}{3}x + \frac{13}{3}$

21. $y = -\frac{1}{2}x + \frac{3}{2}$

22. $y = -2x + 7$

23. $y = -2$

24. $x = -1$

25. $y = 1$

26. $x = -5$

27. $y = 3x - 11$

§5-3**SYSTEMS OF LINEAR RELATIONS****Procedure****Solving Two Linear Equations by Substitution**

- Step 1: Choose either variable and solve one of the equations for that variable.
 Step 2: Substitute the result into the other equation.
 This will produce an equation with one variable.
 Step 3: Solve the equation for the remaining variable.
 Step 4: To find the other variable, substitute the result from *Step 3* into the equation developed in *Step 1*.
 Step 5: Write the solution as an ordered pair and check the answer.

Example 1

Solve the system of linear equations $\begin{cases} 2x + 3y = 8 \\ 4x + 3y = 4 \end{cases}$ by the substitution method.

Solution

Step 1: Choosing the first equation, solve for x .

$$\begin{aligned} 2x + 3y &= 8 \\ 2x &= 8 - 3y \\ x &= \frac{8 - 3y}{2} \end{aligned}$$

Step 2: Now substitute this expression for x into the second equation.

$$\begin{aligned} 4x + 3y &= 4 \\ 4\left(\frac{8 - 3y}{2}\right) + 3y &= 4 \end{aligned}$$

Step 3: Now solve this single variable equation for y .

$$\begin{aligned} 2(8 - 3y) + 3y &= 4 \\ 16 - 6y + 3y &= 4 \\ 16 - 3y &= 4 \\ -3y &= -12 \\ y &= 4 \end{aligned}$$

Step 4: Finally substitute the result $y = 4$ into $x = \frac{8 - 3y}{2}$ from *Step 1*.

$$x = \frac{8 - 3y}{2} = \frac{8 - 3(4)}{2} = \frac{8 - 12}{2} = -\frac{4}{2} = -2$$

Step 5: The solution to the system is $(-2, 4)$. Check this solution in both equations.

$$\begin{array}{ll} 2x + 3y \stackrel{?}{=} 8 & 4x + 3y \stackrel{?}{=} 4 \\ 2(-2) + 3(4) \stackrel{?}{=} 8 & 4(-2) + 3(4) \stackrel{?}{=} 4 \\ -4 + 12 \stackrel{?}{=} 8 & -8 + 12 \stackrel{?}{=} 4 \\ 8 \neq 8\checkmark & 4 = 4\checkmark \end{array}$$

Procedure**Solving Two Linear Equations by Elimination**

- Step 1: Write both equations in standard form: $Ax + By = C$.
- Step 2: Multiply one or both of the equations by appropriate numbers so that the coefficients of either x or y are the same.
- Step 3: Add or subtract the two equations to produce an equation with only one variable.
- Step 4: Solve the equation for the remaining variable.
- Step 5: To find the other variable, substitute the result from *Step 4* into either of the two original equations.
- Step 6: Write the solution as an ordered pair and check the answer.

Example 2

Solve the system of linear equations $\begin{cases} 2x - y - 12 = 0 \\ 3x + 2y + 3 = 0 \end{cases}$ by the elimination method.

Solution

Step 1: Write both equations in standard form: $\begin{cases} 2x - y = 12 \\ 3x + 2y = -3 \end{cases}$

Step 2: Multiply the first equation by 2 to make the coefficients of y equal.

$$\begin{aligned} 2x - y &= 12 \\ 2(2x - y) &= 2(12) \\ 4x - 2y &= 24 \end{aligned}$$

Step 3: Next, add the two equations together to eliminate the y variable.

$$\begin{array}{r} 4x - 2y = 24 \\ + \quad 3x + 2y = -3 \\ \hline 7x + 0y = 21 \end{array}$$

Step 4: Now solve this single variable equation for x .

$$\begin{aligned} 7x &= 21 \\ x &= 3 \end{aligned}$$

Step 5: Finally, substitute the result $x = 3$ into $3x + 2y + 3 = 0$ we can solve for y .

$$\begin{aligned} 3x + 2y + 3 &= 0 \\ 3(3) + 2y + 3 &= 0 \\ 2y + 12 &= 0 \\ 2y &= -12 \\ y &= -6 \end{aligned}$$

Step 6: The solution to the system is $(3, -6)$. Check this solution in both equations.

$$\begin{array}{rcl} 2x - y - 12 & ? & 0 \\ 2(3) - (-6) - 12 & ? & 0 \\ 6 + 6 - 12 & ? & 0 \\ 0 & = & 0\checkmark \end{array} \qquad \begin{array}{rcl} 3x + 2y + 3 & ? & 0 \\ 3(3) + 2(-6) + 3 & ? & 0 \\ 9 - 12 + 3 & ? & 0 \\ 0 & = & 0\checkmark \end{array}$$

Solve each system of equations using substitution.

$$1. \begin{cases} 3x + 2y = 12 \\ 2x - 1 = y \end{cases}$$

$$2. \begin{cases} 9x + 5y = -28 \\ x - 3y = 4 \end{cases}$$

$$3. \begin{cases} 5x + 3y = 29 \\ 7 - x = y \end{cases}$$

$$4. \begin{cases} 3x - 5y = 1 \\ 2x - y = 3 \end{cases}$$

$$5. \begin{cases} x = 2y - 11 \\ 19 = 3x + 7y \end{cases}$$

$$6. \begin{cases} y - 3x = -2 \\ 2x + 5y = 7 \end{cases}$$

$$7. \begin{cases} 5x - 8y = -1 \\ 5x - 9 = 3y \end{cases}$$

$$8. \begin{cases} 2x + 3y = 1 \\ 3x + 4y = 2 \end{cases}$$

$$9. \begin{cases} y = 2x + 3 \\ 2 = 3y + x \end{cases}$$

Solve each system of equations using elimination.

$$10. \begin{cases} x + y = 11 \\ x - y = 7 \end{cases}$$

$$11. \begin{cases} 2x - y = 5 \\ 3x + y = 25 \end{cases}$$

$$12. \begin{cases} x + 2y = 12 \\ x - y = 4 \end{cases}$$

$$13. \begin{cases} 2x + 4 = y \\ 5x - y = 2 \end{cases}$$

$$14. \begin{cases} 3x + 2y = 14 \\ x - y = 3 \end{cases}$$

$$15. \begin{cases} 2x + 7y = 4 \\ x + 11 = 3y \end{cases}$$

$$16. \begin{cases} 5x + 2y = 40 \\ 2x + y = 14 \end{cases}$$

$$17. \begin{cases} 4x = y + 9 \\ 8 = 3x - y \end{cases}$$

$$18. \begin{cases} 6x = y + 5 \\ y = 9x + 4 \end{cases}$$

Solve each system of equations using any method.

$$19. \begin{cases} 2x - y = 7 \\ 2x - 3y = 9 \end{cases}$$

$$20. \begin{cases} 2x - y = 8 \\ 3x + y = 17 \end{cases}$$

$$21. \begin{cases} x - y = 8 \\ 2x - 3y = 21 \end{cases}$$

$$22. \begin{cases} 4x - 3y = 5 \\ 10x + 2y = 3 \end{cases}$$

$$23. \begin{cases} 2x + 9y = 2 \\ 3x - 6y = -10 \end{cases}$$

$$24. \begin{cases} x - 2y = 2 \\ 15x + 10y = 2 \end{cases}$$

$$25. \begin{cases} 2x - 3y = 7 \\ 4x + 2y = 30 \end{cases}$$

$$26. \begin{cases} 0.4x - 0.3y = 3.4 \\ 0.6x + 0.9y = 2.4 \end{cases}$$

$$27. \begin{cases} 2x + 1.5y = 10.5 \\ 0.8x - 0.5y = 0.9 \end{cases}$$

$$28. \begin{cases} \frac{1}{2}y = \frac{3}{2}x - 2 \\ \frac{1}{2} = x + \frac{1}{2}y \end{cases}$$

$$29. \begin{cases} \frac{x}{2} + \frac{y}{3} = 10 \\ \frac{x}{3} + \frac{y}{2} = 10 \end{cases}$$

$$30. \begin{cases} \frac{7x}{2} - \frac{5y}{4} = -12 \\ \frac{3x}{2} + 4 = \frac{y}{4} \end{cases}$$

$$31. \begin{cases} \frac{1}{3}x - \frac{1}{3}y = -1 \\ y + \frac{1}{2}x = 0 \end{cases}$$

$$32. \begin{cases} \frac{3x}{4} + \frac{5y}{2} = 8 \\ \frac{3x}{2} - 5 = \frac{y}{2} \end{cases}$$

$$33. \begin{cases} \frac{x+1}{3} - \frac{y}{4} = -1 \\ \frac{y}{3} - \frac{3x+1}{4} = 0 \end{cases}$$

- | | | | | | | | |
|-----|--------------------------------|-----|--------------------------------|-----|--------------------------------|-----|---|
| 1. | (2, 3) | 2. | (-2, -2) | 3. | (4, 3) | 4. | (2, 1) |
| 5. | (-3, 4) | 6. | (1, 1) | 7. | (3, 2) | 8. | (2, -1) |
| 9. | (-1, 1) | 10. | (9, 2) | 11. | (6, 7) | 12. | $\left(\frac{20}{3}, \frac{8}{3}\right)$ |
| 13. | (2, 8) | 14. | (4, 1) | 15. | (-5, 2) | 16. | (12, -10) |
| 17. | (1, -5) | 18. | (-3, -23) | 19. | (3, -1) | 20. | (5, 2) |
| 21. | (3, -5) | 22. | $\left(\frac{1}{2}, -1\right)$ | 23. | $\left(-2, \frac{2}{3}\right)$ | 24. | $\left(\frac{3}{5}, -\frac{7}{10}\right)$ |
| 25. | $\left(\frac{13}{2}, 2\right)$ | 26. | (7, -2) | 27. | (3, 3) | 28. | (1, -1) |
| 29. | (12, 12) | 30. | (-2, 4) | 31. | (-2, 1) | 32. | (4, 2) |
| 33. | (5, 12) | | | | | | |

§5-4**FUNCTIONS****Definition**

A **function** is a rule that assigns a unique real number to each number in a specified set of real numbers.

Functions are expressed in the form $f(x) = u$ where u is a variable expression. $f(x)$ does not indicate that f is multiplied times x but rather that the function f should be evaluated at the value x .

Example 1

Evaluate the function $f(x) = 2x^2 + 11x - 7$ at the indicated values.

- a. $x = 2$ b. $x = -1$ c. $x = t$ d. $x = b + 1$

Solution

a. $f(2) = 2(2)^2 + 11(2) - 7 = 2(4) + 22 - 7 = 8 + 15 = 23$

b. $f(-1) = 2(-1)^2 + 11(-1) - 7 = 2(1) - 11 - 7 = 2 - 18 = -16$

c. $f(t) = 2(t)^2 + 11(t) - 7 = 2t^2 + 11t - 7$

d. $f(b + 1) = 2(b + 1)^2 + 11(b + 1) - 7 = 2(b^2 + 2b + 1) + 11b + 11 - 7$
 $= 2b^2 + 4b + 2 + 11b + 4 = 2b^2 + 15b + 6$

Theorem**The Vertical Line Test**

If a vertical line drawn anywhere on the graph of a relation (in x and y) will intersect the graph at no more than one point, then the relation is a function of x .

Example 2

Use the vertical line test to determine which of the following relations are functions of x .

a.

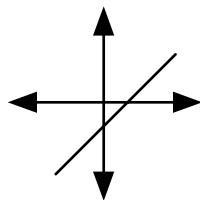

b.

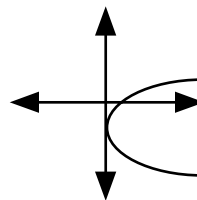

c.

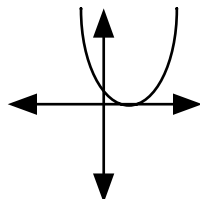

d.

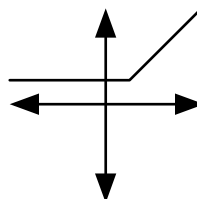
**Solution**

a. This is a function since any vertical line will intersect the graph at one point.

b. This is not a function many vertical lines will intersect the graph at two points.

c. This is a function since any vertical line will intersect the graph at one point.

d. This is a function since any vertical line will intersect the graph at one point.

Functions can be *translated* (moved) by using the following rules.

Properties

<u>Function</u>	<u>Description</u>
$g(x) = f(x) + k$	$g(x)$ is $f(x)$ translated k units up
$g(x) = f(x) - k$	$g(x)$ is $f(x)$ translated k units down
$g(x) = f(x - h)$	$g(x)$ is $f(x)$ translated h units to the right
$g(x) = f(x + h)$	$g(x)$ is $f(x)$ translated h units to the left

Example 3

Use the graph of $f(x)$ below to graph each of the following functions.

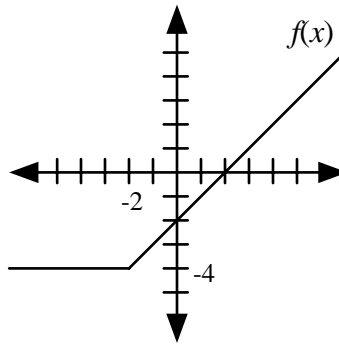

a. $g(x) = f(x) + 3$

b. $h(x) = f(x) - 1$

c. $u(x) = f(x - 3)$

d. $v(x) = f(x + 2)$

Solution

a. $g(x)$ is $f(x)$ translated 3 units up.

b. $h(x)$ is $f(x)$ translated 1 unit down.

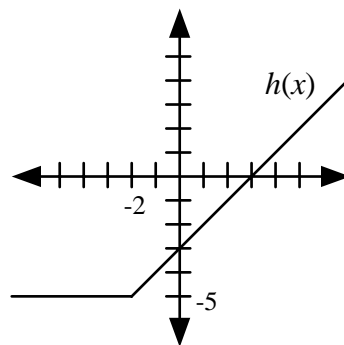
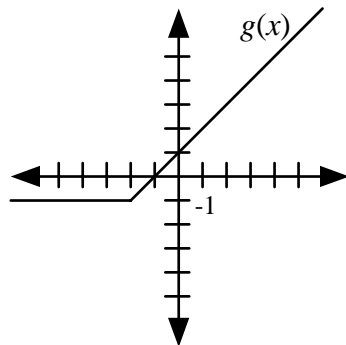

c. $u(x)$ is $f(x)$ translated right 3 units.

d. $v(x)$ is $f(x)$ translated left 2 units.

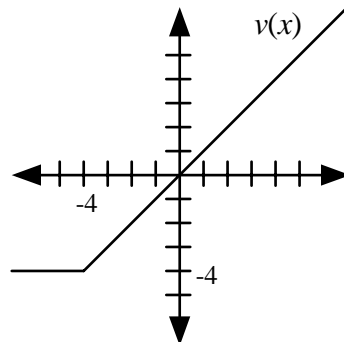
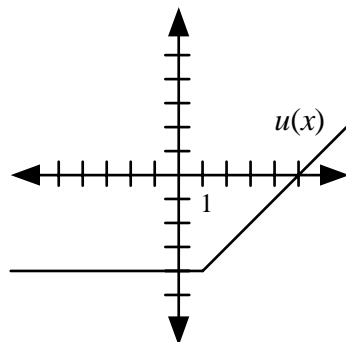

Evaluate each function at the indicated values.

1. $f(x) = 2x + 5; x = -3$

2. $g(x) = x^2 - 1; x = 2$

3. $h(t) = |t - 2| + 1; t = -3$

4. $f(a) = \frac{a+1}{3a-7}; a = 3$

5. $g(x) = 5 - \sqrt{x+2}; x = 14$

6. $h(x) = 2^x + 1; x = 4$

7. $u(r, s) = \frac{2r+1}{s}; r = 5, s = -2$

8. $g(x, y) = xy - 2y + \sqrt{y}; x = -1, y = 4$

Evaluate the function $f(x)$ at the indicated values: $f(x) = \frac{2x+2}{2x-3}$

9. $f(0)$

10. $f(3)$

11. $f(a)$

12. $f(x+1)$

Evaluate the function $g(x)$ at the indicated values: $g(x) = 2x^2 + x - 2$

13. $g(0)$

14. $g(3)$

15. $g(a)$

16. $g(x+1)$

Use the function $f(x)$ to determine $g(x)$ in each case: $f(x) = 3x^2 - x - 1$.

17. $g(x) = f(x) + 5$

18. $g(x) = f(x) - 1$

19. $g(x) = f(x - 3)$

20. $g(x) = f(x + 2)$

21. $g(x) = f(x - 1) + 2$

22. $g(x) = f(x + 2) - 3$

Use the graph of the function $f(x)$ to draw the graph of $g(x)$ in each case.

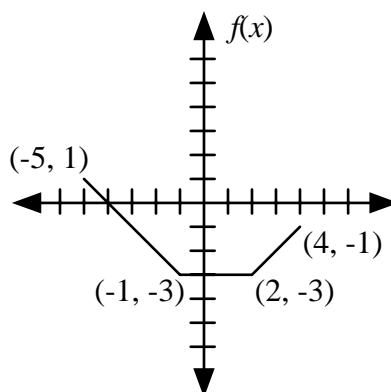

23. $g(x) = f(x) + 3$

24. $g(x) = f(x) - 2$

25. $g(x) = f(x + 1)$

26. $g(x) = f(x - 2)$

27. $g(x) = f(x - 1) + 2$

28. $g(x) = f(x + 2) - 1$

1. -1 2. 3 3. 6 4. 2 5. 1
6. 17 7. $-\frac{11}{2}$ 8. -10 9. $-\frac{2}{3}$ 10. $\frac{8}{3}$
11. $\frac{2a+2}{2a-3}$ 12. $\frac{2x+4}{2x-1}$ 13. -2 14. 19 15. $2a^2 + a - 2$
16. $2x^2 + 5x + 1$ 17. $3x^2 - x + 4$ 18. $3x^2 - x - 2$ 19. $3x^2 - 19x + 29$
20. $3x^2 + 11x + 9$ 21. $3x^2 - 7x + 5$ 22. $3x^2 + 11x + 6$

23.

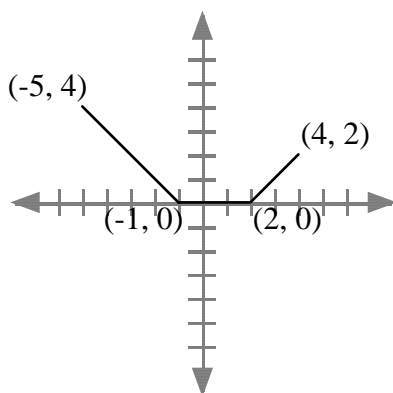

24.

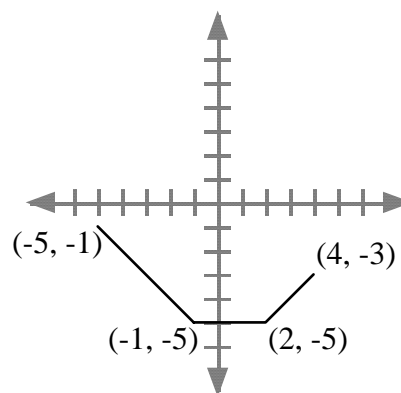

25.

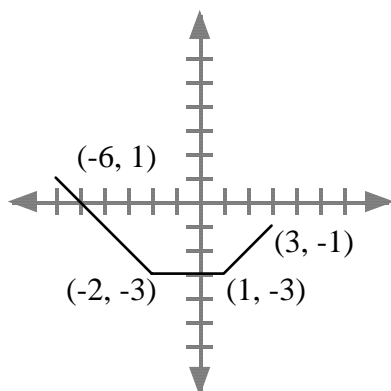

26.

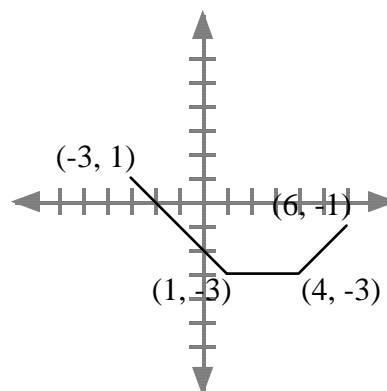

27.

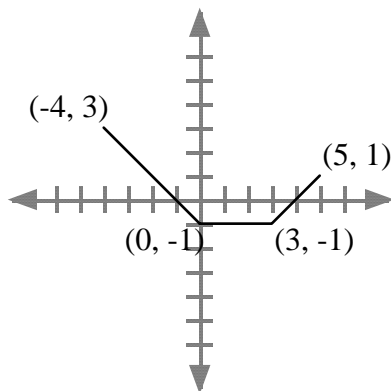

28.

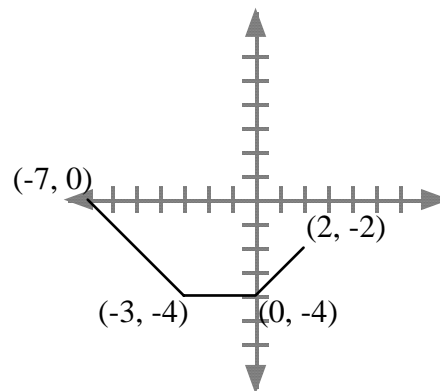

§6-1**PERIMETER AND CIRCUMFERENCE****Definition**

Perimeter is a measure of the distance around a figure.

For a polygon, the perimeter is the sum of the lengths of its sides. For a circle, the measure of the distance around a circle is called the circumference.

Definition

The circumference of a circle is the perimeter of the circle.

Formula

The circumference of a circle is given by the equation: $C = 2\pi r$ where r is the radius of the circle (the distance from the center of the circle to its edge).

The diameter of a circle is twice its radius.

Example 1

For the diagram below, find the perimeter of the square and the circumference of the circle.

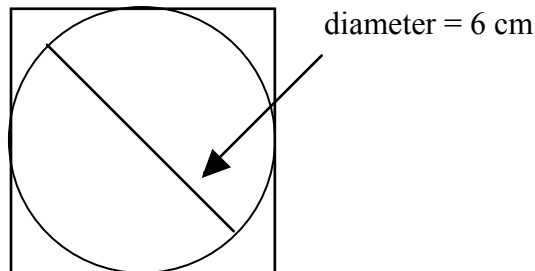
**Solution**

Since the circle is inscribed inside the square, the diameter of circle is equal in length to the side of the square. Since the square has four equal sides, its perimeter is:

$$6 \text{ cm} + 6 \text{ cm} + 6 \text{ cm} + 6 \text{ cm} = 24 \text{ cm}$$

Since the diameter of the circle is 6 cm its circumference is given by:

$$C = 2\pi r = 2\pi \cdot 6 = 12\pi$$

Example 2

A certain square has the same perimeter as a 10 by 2 foot rectangle. How long is a side of the square?

Solution

The length of the rectangle is 10 ft and its width is 2 feet so its perimeter is given by:

$$P = 2l + 2w = 2 \cdot 10 + 2 \cdot 2 = 24$$

Since the square has four equal side lengths, each of its sides is one-fourth of 24 ft. Therefore the square has sides which are 6 ft in length.

Example 3

The width of a rectangle is twice its length. If its perimeter is 27 cm, find the length and width.

Solution

If the length is given by l , then the width is $w = 2l$. Therefore

$$P = 2l + 2w = 2l + 2(2l) = 2l + 4l = 6l$$

Thus $6l = 27$ and $l = 4.5$. So the length is 4.5 cm and the width is 9 cm.

Find the perimeter of each figure below.

1.

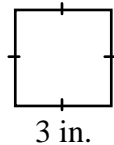

2.

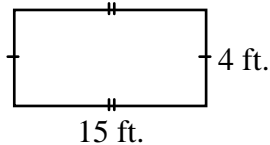

3.

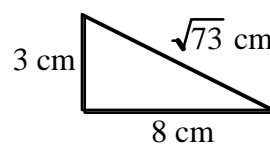

4.

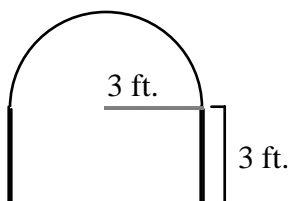

5.

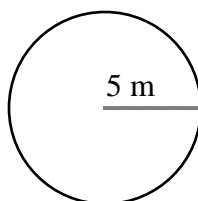

6.

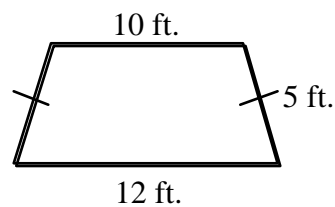

For each shape below find an expression for the perimeter.

7.

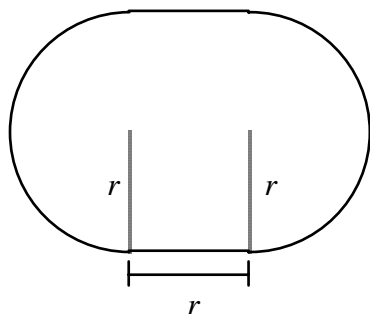

8.

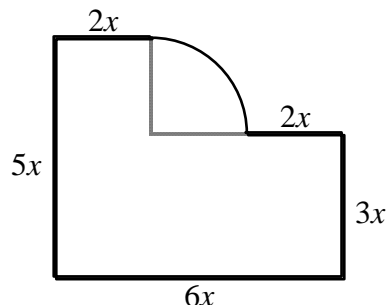

For each shape below use the perimeter, p , to find x .

9. $p = 46$

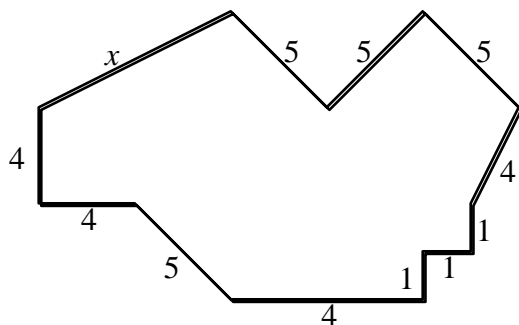

10. $p = 52$

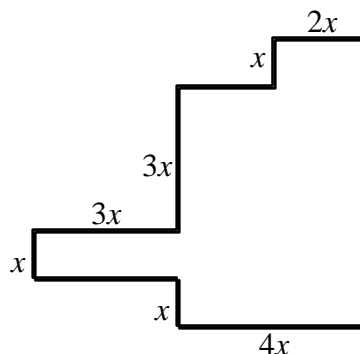

- | | | | | | | | |
|----|-----------|-----|--------|----|---------------------|----|-----------------|
| 1. | 12 in. | 2. | 38 ft. | 3. | $11 + \sqrt{73}$ cm | 4. | $12 + 3\pi$ ft. |
| 5. | 10π m | 6. | 32 ft. | 7. | $2r(1 + \pi)$ | 8. | $x(18 + \pi)$ |
| 9. | 7 | 10. | 2 | | | | |

§6-2**AREA****Definition**

The area of a two-dimensional figure is a measure of the number of square units required to completely cover the figure.

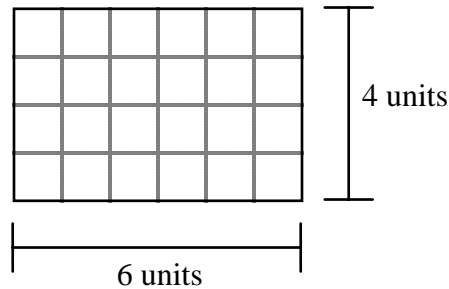

It takes 24 square units to cover the rectangle shown above. Thus, the area of the rectangle is 24 square units. Be careful not to confuse area with perimeter. Remember, area is always measured in square units such as square feet (ft^2) or square inches (in^2).

Formulas**Areas of common shapes****Formulas**

Rectangles: the length times the width

$$A = lw.$$

Squares: the square of the length of the side

$$A = s^2$$

Parallelograms: the length of the base times the height

$$A = bh.$$

Trapezoids: one-half the height times the sum of the bases

$$A = \frac{1}{2}(b + B)h$$

Triangles: one-half the length of the base times the height

$$A = \frac{1}{2}bh$$

Circle: π times the square of the radius

$$A = \pi r^2$$

Example 1 Find the area of the triangle shown below.

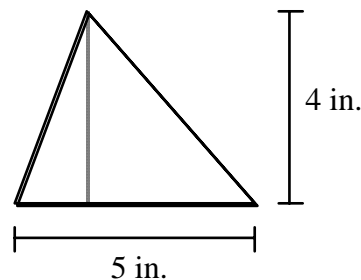
**Solution**

The base of the triangle is 5 in. and the height of the triangle is 4 in. Thus

$$A = \frac{1}{2}bh = \frac{1}{2} \cdot 5 \cdot 4 = 10 \text{ square in.}$$

Example 2 For the diagram below, find the area of the square and the area of the circle.

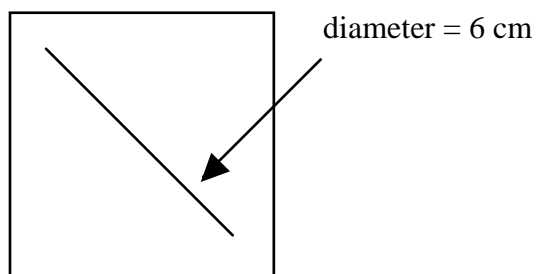

Solution Since the circle is inscribed inside the square, the diameter of circle is equal in length to the side of the square. Thus the square has area $A = s^2 = 6^2 = 36$ square cm

Since the diameter of the circle is 6 cm, the radius of the circle is 3 cm.
Thus $A = \pi r^2 = \pi 3^2 = 9\pi$ square cm.

Example 3 Find the area of the parallelogram shown below.

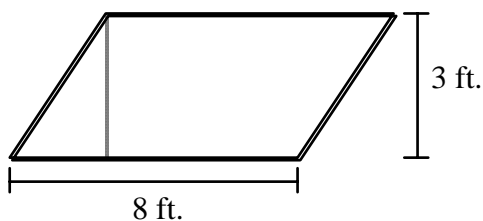

Solution The base of the parallelogram is 8 ft. and the height is 3 ft. Thus $A = bh = 8 \cdot 3 = 24$ square feet

Example 4 Find the area of the trapezoid shown below.

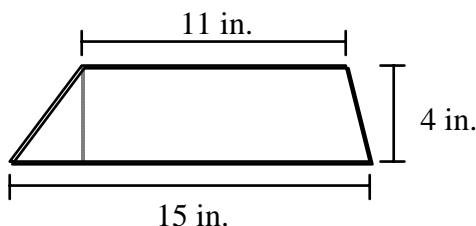

Solution The bases are 15 in. and 11 in. while the height is 4 in.
Thus $A = \frac{1}{2}(b + B)h = \frac{1}{2}(11 + 15)4 = \frac{1}{2}(26)4 = 52$ square inches

Theorem If all of the dimensions of a plane figure are multiplied by a factor a , then the area of the figure is multiplied by a factor of a^2 .

Example 5 If the radius of circle B is three times the radius of circle C , and the area of circle B is A , then what is the area of circle C ?

Solution Since the dimensions of circle C are 3 times that of circle B , the area of circle C must be $3^2 = 9$ times that of circle B . So circle C has an are of $9A$.

Find the area of each figure below.

1.

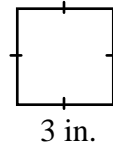

2.

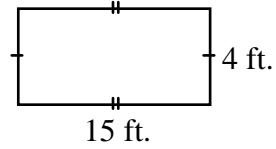

3.

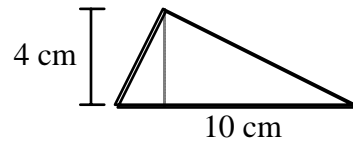

4.

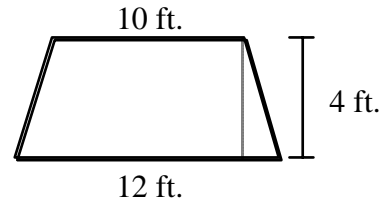

5.

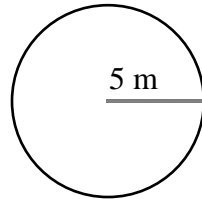

6.

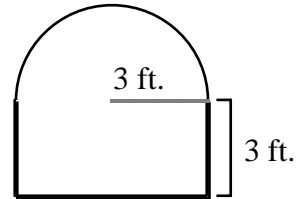

For each figure below find the area of the shaded region.

7.

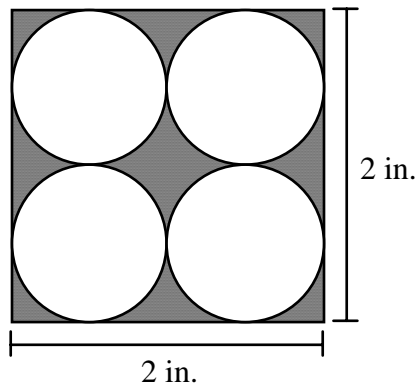

8.

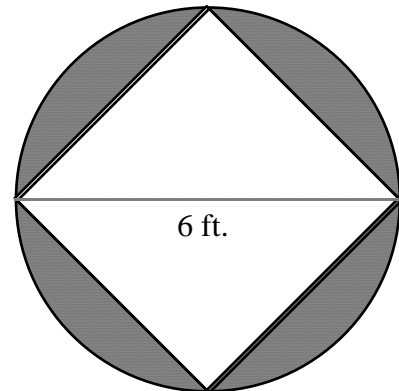

Solve each word problem below.

9. A certain square has a side which is 10 inches long. If a circle has the same area as the square then what is its radius?
10. A rectangle is twice as long as it is wide. If it has an area of 24.5 square centimeters, then what are the length and height?

1. 9 sq. in. 2. 60 sq. ft. 3. 20 sq. cm 4. 44 sq. ft.
5. 25π sq. m 6. $18 + \frac{9}{2}\pi$ sq. ft. 7. $4 - \pi$ sq. in.
8. $9\pi - 18$ sq. ft. 9. $\frac{10\sqrt{\pi}}{\pi}$ in. 10. width = 3.5 cm, length = 7 cm

§6-3**VOLUME****Definition**

The **volume** of a three-dimensional solid is the number of cubic units contained within the solid.

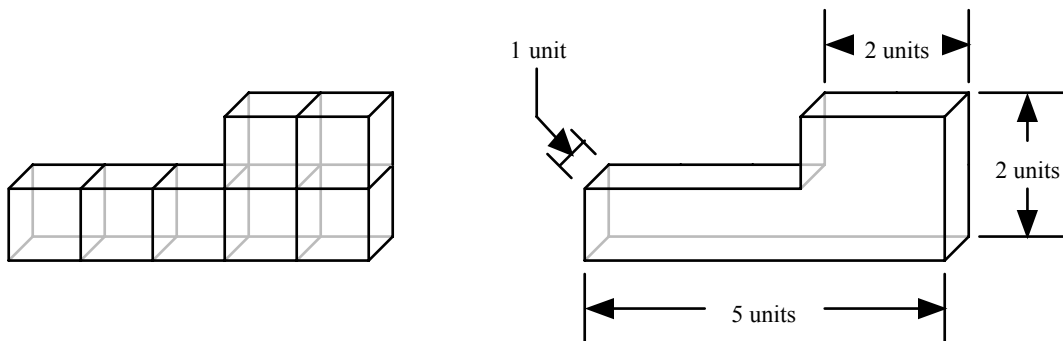

The volume of the solid shown above is 7 cubic units.

Formula

The **volume of a prism** with base area A and height h is given by: $V = Ah$

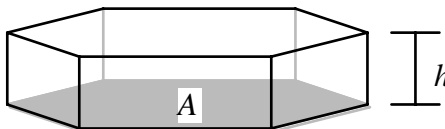
**Example 1**

What is the side length of a cube whose volume is 27 cubic inches.

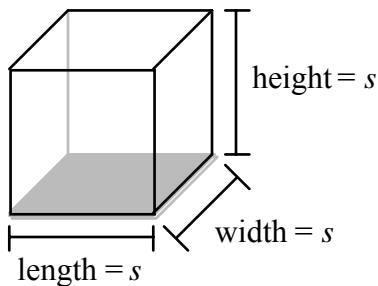
**Solution**

All of the sides of a cube have the same length, s , so the area of the base is $A = s^2$ and the height is s . From the formula above, the volume is: $V = Ah = (s^2)(s) = s^3$.

$$\begin{aligned} V &= 27 \\ s^3 &= 27 \\ \sqrt[3]{s^3} &= \sqrt[3]{27} \\ s &= 3 \end{aligned}$$

So each side is 3 inches in length.

Example 2 A prism has a height of 12 cm and an irregular hexagonal base which is 23 square inches in area. Find the volume of the prism.

Solution $V = Ah = (23)(12) = 276$ cubic inches.

Example 3 Find the volume of a cylinder with a radius of 2 inches and height of 7 inches.

Solution Since the base of the cylinder is a circle, its area is $A = \pi r^2 = \pi(2)^2 = 4\pi$. Thus we have: $V = Ah = (4\pi)(7) = 28\pi$ cubic inches.

The process above leads to the following formula.

Formula

The **volume of a right circular cylinder** is given by: $V = \pi r^2 h$.

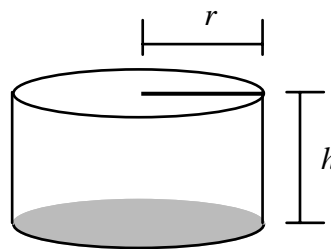

Example 4 A 10 foot high right circular cylindrical tank is completely filled with water. If the volume of the water is 27π cubic feet then what is the radius of the tank?

Solution

$$\begin{aligned} V &= \pi r^2 h \\ \frac{V}{\pi h} &= \frac{\pi r^2 h}{\pi h} \\ \frac{V}{\pi h} &= r^2 \\ \sqrt{\frac{V}{\pi h}} &= \sqrt{r^2} \\ \text{thus } r &= \sqrt{\frac{V}{\pi h}} \end{aligned}$$

So in this case $r = \sqrt{\frac{V}{\pi h}} = \sqrt{\frac{27\pi}{10\pi}} = \sqrt{\frac{27}{10}} \approx 0.927$ feet.

Formula

The **volume of a sphere** is given by: $V = \frac{4}{3} \pi r^3$, where r is the radius of the sphere.

Example 5 Calculate the volume of a sphere with a radius of 4 inches.

Solution $V = \frac{4}{3} \pi r^3 = \frac{4}{3} \pi (4)^3 = \frac{256\pi}{3}$

Find the volume of each figure below.

1. Right Circular Cylinder

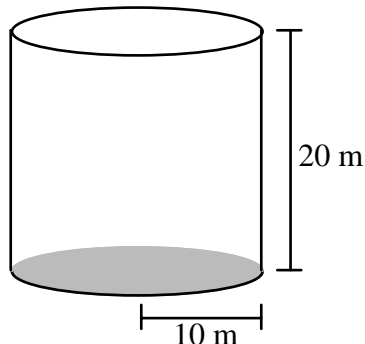

2. Right Square Prism

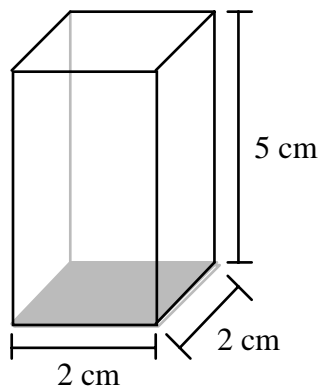

3. Sphere

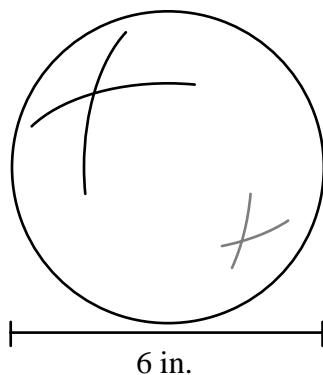

4. Right Prism

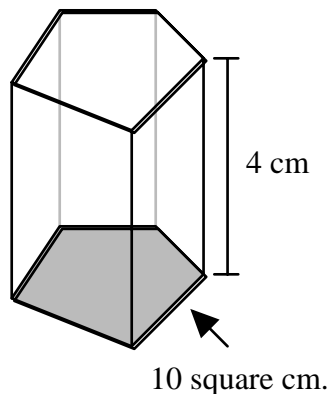

Solve each word problem below.

5. A cylindrical building has a diameter of 350 feet and a height of 980 feet. What is the volume of this building?
6. A classroom is 31 feet long, 28 feet wide and 12 feet high. Find its volume.
7. The radius of the Earth is approximately 6.378×10^6 meters. What is the volume of the Earth?
8. A right triangular prism is 4 inches high. If the volume is 122 cubic inches, then what is the area of the base?
9. A nickel has a diameter of approximately 20 mm, and a \$2 stack of nickels is about 76 mm high. Find the volume of a single nickel.
10. A sphere and a cube have the same volume. If the sphere has a radius of 5 in., then what is the length of a side of the cube?

1. 2000π cu. m 2. 20 cu. cm 3. 36π cu. in. 4. 40 cu. cm
5. $30,012,500\pi$ cu. ft. 6. 10,416 cu. ft. 7. 1.09×10^{21} cu. m
8. 30.5 sq. in. 9. 190π cu. mm 10. $\sqrt[3]{\frac{500\pi}{3}}$ cu. in.

§6-4

ANGLES IN A PLANE

Definition

A pair of **supplementary angles** have measures which add to 180° .

Definition

A pair of **complementary angles** have measures which add to 90° .

Definition

Parallel lines are lines that lie in a same plane (**coplanar**) but do not intersect.

Definition

A **transversal** is a line that intersects two coplanar lines.

The figure below represents a transversal intersecting two parallel lines to form eight angles. The region between the lines l and m is called the **interior region**. The region not between lines l and m is called the **exterior region**. Angles that are on opposite sides of the transversal are referred to as **alternate angles**.

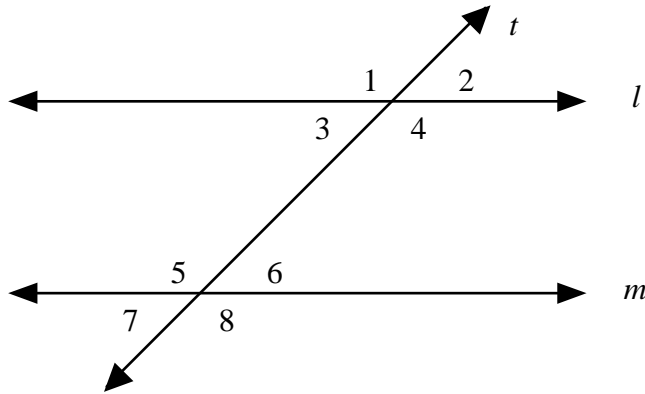

Properties

<u>Angle Pair</u>	<u>Measures</u>	<u>Examples</u>
Alternate Interior	equal	$\angle 4$ and $\angle 5$; $\angle 3$ and $\angle 6$
Same Side Interior	supplementary	$\angle 3$ and $\angle 5$; $\angle 4$ and $\angle 6$
Alternate Exterior	equal	$\angle 1$ and $\angle 8$; $\angle 2$ and $\angle 7$
Same Side Exterior	supplementary	$\angle 1$ and $\angle 7$; $\angle 2$ and $\angle 8$
Corresponding	equal	$\angle 1$ and $\angle 5$; $\angle 2$ and $\angle 6$ $\angle 3$ and $\angle 7$; $\angle 4$ and $\angle 8$
Vertical	equal	$\angle 1$ and $\angle 4$; $\angle 2$ and $\angle 3$ $\angle 5$ and $\angle 8$; $\angle 6$ and $\angle 7$

Example 1 If $m\angle 1 = 115^\circ$ in the previous diagram, then find the measures of the other angles.

Solution

$\angle 1$ and $\angle 2$ are supplementary and so $m\angle 2 = 180^\circ - 115^\circ = 65^\circ$.

$\angle 1$ and $\angle 3$ are supplementary and so $m\angle 3 = 180^\circ - 115^\circ = 65^\circ$.

$\angle 1$ and $\angle 4$ are vertical angles and so $m\angle 4 = 115^\circ$.

$\angle 1$ and $\angle 5$ are corresponding angles and so $m\angle 5 = 115^\circ$.

$\angle 5$ and $\angle 6$ are supplementary and so $m\angle 6 = 180^\circ - 115^\circ = 65^\circ$.

$\angle 1$ and $\angle 7$ are same side exterior angles and so $m\angle 7 = 180^\circ - 115^\circ = 65^\circ$.

$\angle 1$ and $\angle 8$ are alternate exterior angles and so $m\angle 8 = 115^\circ$.

Thus we see that $m\angle 1 = m\angle 4 = m\angle 5 = m\angle 8 = 115^\circ$ and

$$m\angle 2 = m\angle 3 = m\angle 6 = m\angle 7 = 65^\circ$$

Theorem

The Angle-Sum Theorem for Polygons

The sum, S , of the measures of the interior angles of a convex polygon with n sides is:

$$S = (n - 2)180^\circ$$

Example 2

In the figure below, find x .

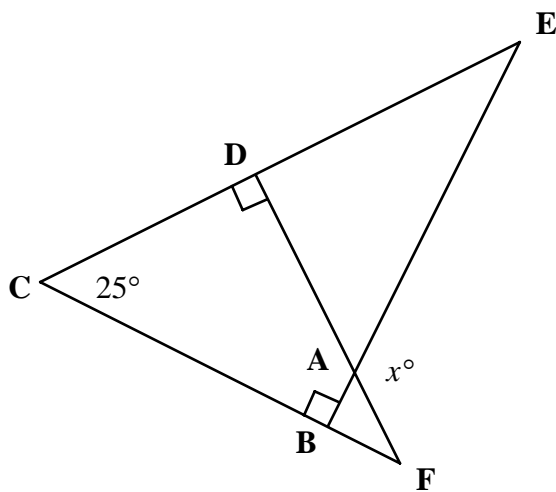

Solution

By the angle-sum theorem, the polygon sum of the interior angles of polygon **ABCD** is $(4 - 2)180^\circ = 2 \cdot 180^\circ = 360^\circ$.

Since $m\angle C = 25^\circ$, $m\angle CDA = 90^\circ$ and $m\angle CBA = 90^\circ$ there are 205° accounted for.

Thus $m\angle DAB = 360^\circ - 205^\circ = 155^\circ$.

Since $\angle DAB$ and $\angle EAF$ are vertical angles, they must have the same measure.

Therefore $x = 155$.

In the figure below the lines l and m are parallel. Find the measure of each angle.

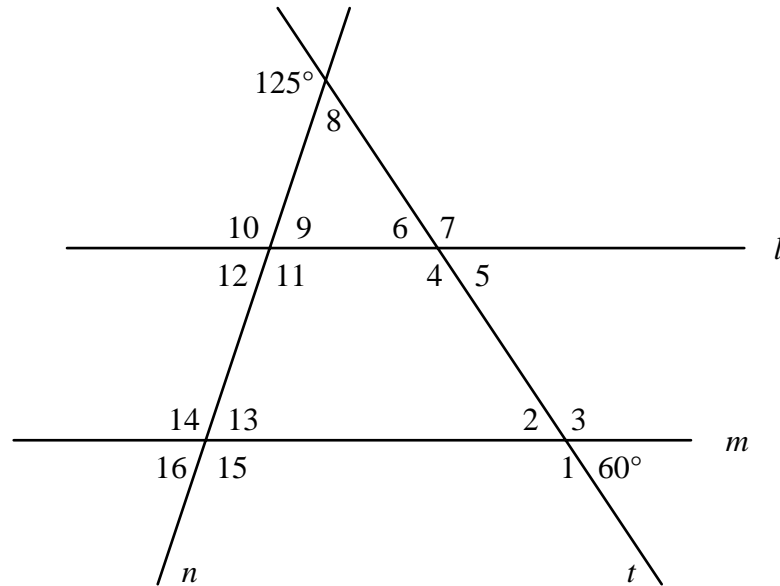

- | | | | |
|------------------|------------------|------------------|------------------|
| 1. $m\angle 1$ | 2. $m\angle 2$ | 3. $m\angle 3$ | 4. $m\angle 4$ |
| 5. $m\angle 5$ | 6. $m\angle 6$ | 7. $m\angle 7$ | 8. $m\angle 8$ |
| 9. $m\angle 9$ | 10. $m\angle 10$ | 11. $m\angle 11$ | 12. $m\angle 12$ |
| 13. $m\angle 13$ | 14. $m\angle 14$ | 15. $m\angle 15$ | 16. $m\angle 16$ |
| 17. Find x | 18. Find x | | |

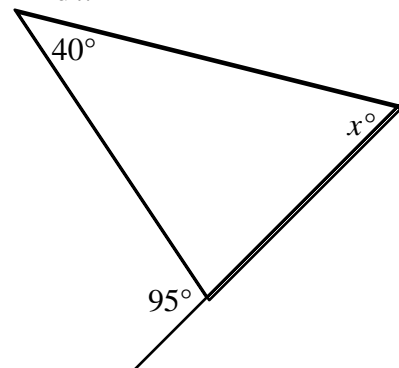
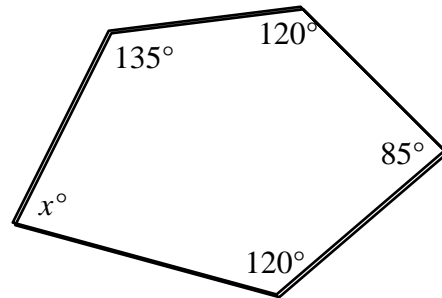

19. What is the sum of the interior angles of a convex pentagon (5-sided polygon)?
20. What is the sum of the interior angles of a convex octagon (8-sided polygon)?
21. What is the measure of each interior angle of a convex, regular, 25 sided polygon?
22. What is the measure of each interior angle of a convex, regular, 30 sided polygon?

- | | | | |
|------------------|------------------|-----------------|------------------|
| 1. 120° | 2. 60° | 3. 120° | 4. 120° |
| 5. 60° | 6. 60° | 7. 120° | 8. 55° |
| 9. 65° | 10. 115° | 11. 115° | 12. 65° |
| 13. 65° | 14. 115° | 15. 115° | 16. 65° |
| 17. 80° | 18. 55° | 19. 540° | 20. 1080° |
| 21. 4140° | 22. 5040° | | |

§6-5

SPECIAL TRIANGLES

Definition

Two triangles are **similar** if corresponding angles are equal in measure. For similar triangles corresponding sides are in proportion.

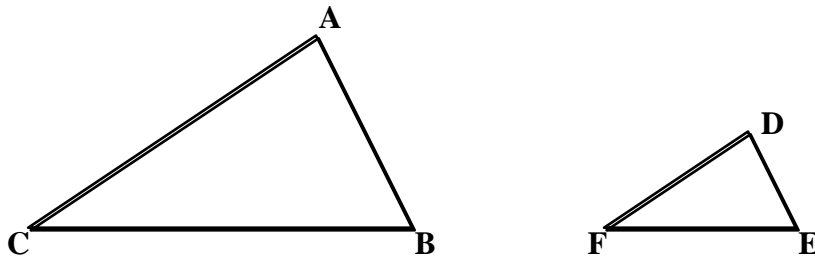

If triangle **ABC** and triangle **DEF** are similar ($\triangle ABC \sim \triangle DEF$) then

$$m\angle A = m\angle D, m\angle B = m\angle E, m\angle C = m\angle F \text{ and } \frac{AB}{DE} = \frac{BC}{EF} = \frac{CA}{FD}.$$

Theorem

If a pair of triangles has two pairs of congruent corresponding angles then they are similar.

Example 1

In the figure below, find x and y .

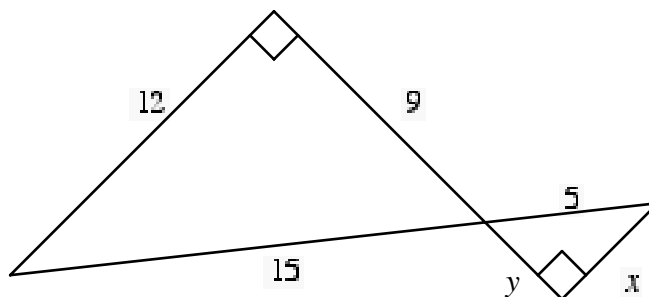

Solution

Where the triangles meet they form vertical angles. Since the vertical angles are equal in measure and each triangle also has one right angle, the two triangles are similar. Since the ratios of corresponding sides are equal we have the following proportion.

$$\frac{x}{12} = \frac{5}{15}$$

Solving for x produces...

$$\begin{aligned} 15x &= 12 \cdot 5 \\ 15x &= 60 \\ x &= 4 \end{aligned}$$

Similarly since the sides of the small triangle are one-third the length of their corresponding sides in the larger triangle, $y = 3$.

Definition

A triangle with two equal sides is called an **isosceles triangle**. The angles opposite the two equal sides are equal in measure.

Definition

A triangle with three equal sides is called an **equilateral triangle**. All three angles of an equilateral triangle are 60° .

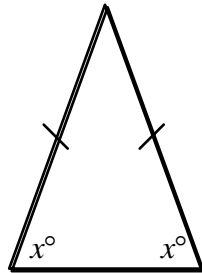

Isosceles

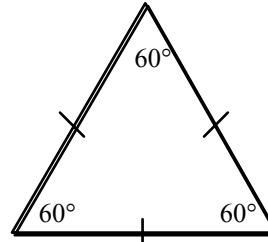

Equilateral

Theorem**Pythagorean Theorem**

In a right triangle, the square of the length of the hypotenuse is equal to the sum of the squares of the lengths of the legs.

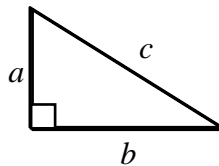

$$c^2 = a^2 + b^2$$

Example 2

Find y for each of the triangles below.

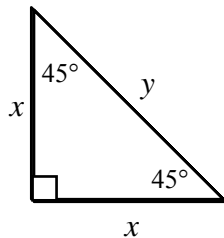
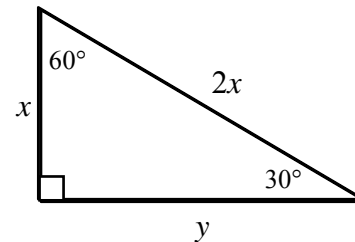
a.**b.****Solution**

$$\begin{aligned} \text{a. } y^2 &= x^2 + x^2 \\ y^2 &= 2x^2 \\ \sqrt{y^2} &= \sqrt{2x^2} \\ y &= x\sqrt{2} \end{aligned}$$

$$\begin{aligned} \text{b. } x^2 + y^2 &= (2x)^2 \\ x^2 + y^2 &= 4x^2 \\ y^2 &= 3x^2 \\ \sqrt{y^2} &= \sqrt{3x^2} \\ y &= x\sqrt{3} \end{aligned}$$

These triangles are examples of two common types named after their angle measures: a 45-45-90 triangle and a 30-60-90 triangle. A 45-45-90 triangle is an isosceles right triangle and has a hypotenuse which is $\sqrt{2}$ times as long as either leg. In a 30-60-90 triangle the hypotenuse is twice as long as the shortest leg while the longer leg is $\sqrt{3}$ times the length of the shorter leg.

Find the length of the third side of each right triangle.

1.

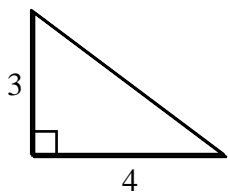

2.

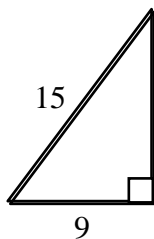

3.

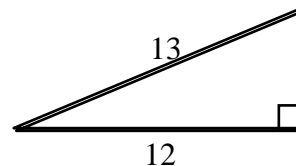

Find an expression for the length of the third side of each right triangle.

4.

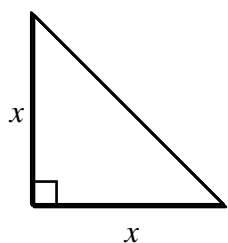

5.

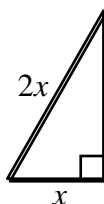

6.

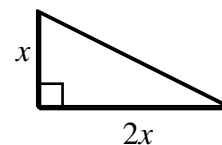

7. Find x

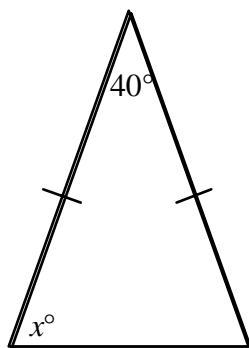

8. Lines l and m are parallel. Find x .

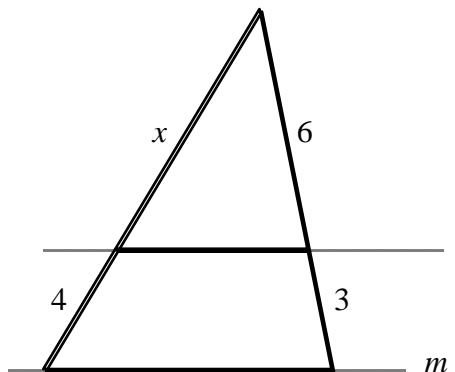

9. Solve for x and y .

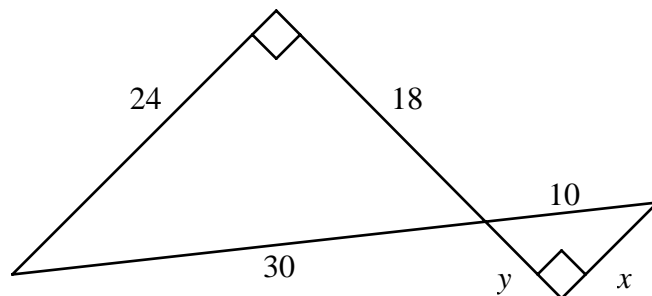

1. 5
2. 12
3. 5
4. $x\sqrt{2}$
5. $x\sqrt{3}$
6. $x\sqrt{5}$
7. 70°
8. 8
9. $x = 8$ and $y = 6$

§6-6**RIGHT TRIANGLE TRIGONOMETRY**

In this section we consider the trigonometry of right triangles. The trigonometric functions of concern are the *sine*, *cosine* and *tangent* functions.

Definition

For a right triangle, the **sine** of an angle θ is the ratio of the length of the leg opposite θ to the length of the hypotenuse: $\sin \theta = \frac{\text{opposite leg}}{\text{hypotenuse}}$.

Definition

For a right triangle, the **cosine** of an angle θ is the ratio of the length of the leg adjacent θ to the length of the hypotenuse: $\cos \theta = \frac{\text{adjacent leg}}{\text{hypotenuse}}$.

Definition

For a right triangle, the **tangent** of an angle θ is the ratio of the length of the leg opposite θ to the length of the leg adjacent θ : $\tan \theta = \frac{\text{opposite leg}}{\text{adjacent leg}}$.

The mnemonic SOH CAH TOA is often used to recall the relationship of the sides of the right triangle to the trigonometric functions.

Example 1

Find the sine, cosine and tangent of θ and α in the right triangle shown below.

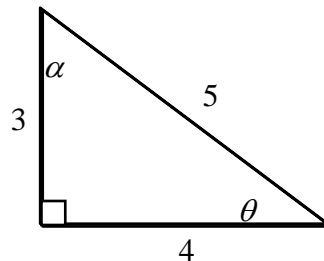
**Solution**

For θ the opposite leg has length 3 and the adjacent leg has length 4. Therefore...

$$\sin \theta = \frac{\text{opposite leg}}{\text{hypotenuse}} = \frac{3}{5} \quad \cos \theta = \frac{\text{adjacent leg}}{\text{hypotenuse}} = \frac{4}{5} \quad \tan \theta = \frac{\text{opposite leg}}{\text{adjacent leg}} = \frac{3}{4}$$

For α the opposite leg has length 4 and the adjacent leg has length 3. Therefore...

$$\sin \alpha = \frac{\text{opposite leg}}{\text{hypotenuse}} = \frac{4}{5} \quad \cos \alpha = \frac{\text{adjacent leg}}{\text{hypotenuse}} = \frac{3}{5} \quad \tan \alpha = \frac{\text{opposite leg}}{\text{adjacent leg}} = \frac{4}{3}$$

Example 2 If $\cos \theta = x$ for the triangle below, then find the length of **AC**.

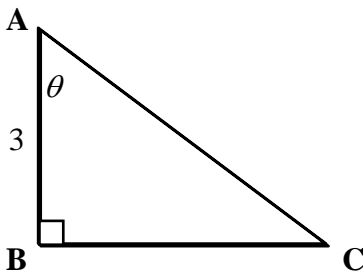

Solution

$$\cos \theta = \frac{\text{adjacent leg}}{\text{hypotenuse}}$$
$$x = \frac{3}{\mathbf{AC}}$$
$$\mathbf{AC}x = 3$$
$$\mathbf{AC} = \frac{3}{x}$$

Identity For any angle θ , $\sin^2 \theta + \cos^2 \theta = 1$.

Example 3 If $\sin \theta = \frac{1}{2}$ then find the cosine of θ .

Solution

$$\sin^2 \theta + \cos^2 \theta = 1$$
$$\cos^2 \theta = 1 - \sin^2 \theta$$
$$\cos^2 \theta = 1 - \left(\frac{1}{2}\right)^2$$
$$\cos^2 \theta = \frac{3}{4}$$
$$\cos \theta = \pm \frac{\sqrt{3}}{2}$$

Identity For any angle θ , $\tan \theta = \frac{\sin \theta}{\cos \theta}$.

Example 4 If $\cos \theta = \frac{5}{13}$ and $\tan \theta = \frac{12}{5}$ then find the sine of θ .

Solution

$$\tan \theta = \frac{\sin \theta}{\cos \theta}$$
$$\tan \theta \cdot \cos \theta = \sin \theta$$
$$\frac{12}{5} \cdot \frac{5}{13} = \sin \theta$$
$$\frac{12}{13} = \sin \theta$$

Find each quantity for the right triangle below.

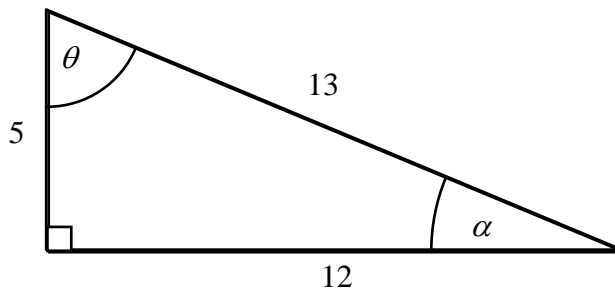

- | | | |
|------------------|------------------|------------------|
| 1. $\sin \alpha$ | 2. $\cos \alpha$ | 3. $\tan \alpha$ |
| 4. $\sin \theta$ | 5. $\cos \theta$ | 6. $\tan \theta$ |

Find the lengths of the missing sides of the right triangle below.

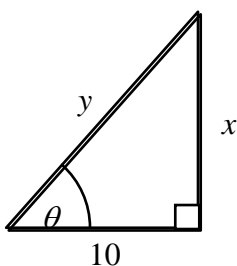

$$\cos \theta = \frac{2}{3}$$

$$\tan \theta = \frac{\sqrt{5}}{2}$$

- | | |
|---------------|---------------|
| 7. Find x . | 8. Find y . |
|---------------|---------------|

Use the given quantities to calculate the missing quantity.

9. If $\sin \theta = \frac{1}{2}$ and $\cos \theta = \frac{\sqrt{3}}{2}$ then find $\tan \theta$.

10. If $\sin \theta = \frac{\sqrt{2}}{2}$ and $\tan \theta = 1$ then find $\cos \theta$.

11. If $\cos \theta = \frac{1}{3}$ and $\tan \theta = 2\sqrt{2}$ then find $\sin \theta$.

12. If $\cos \theta = \frac{\sqrt{5}}{3}$ and $\sin \theta > 0$ then find $\sin \theta$.

1. $\frac{5}{13}$

2. $\frac{12}{13}$

3. $\frac{5}{12}$

4. $\frac{12}{13}$

5. $\frac{5}{13}$

6. $\frac{12}{5}$

7. 15

8. $5\sqrt{5}$

9. $\frac{\sqrt{3}}{3}$

10. $\frac{\sqrt{2}}{2}$

11. $\frac{2\sqrt{2}}{3}$

12. $\frac{2}{3}$

§7-1**COUNTING****Definition****The Multiplication Principle**

If one experiment can result in m possible outcomes and another experiment can result in n possible outcomes then there are mn possible outcomes of the two experiments.

Example 1

If you have four different shirts and three different pairs of pants, how many different outfits can you put together?

Solution

There are four possible choices of shirts and three possible choices for pants so by the multiplication principle there are $4 \times 3 = 12$ possible outfits.

Example 2

If you have three types of bread, two types of cheese and four kinds of meat then, how many different types of sandwich can you make?

Solution

There are $3 \times 2 \times 4 = 24$ possible kinds of sandwich.

Example 3

There are three roads connecting Apple City to Garlic Junction, and 4 roads connecting Garlic Junction to Cantaloupe Village. If these are the only roads available, how many different ways are there to get from Apple City to Cantaloupe Village?

Solution

There are $3 \times 4 = 12$ possible paths.

Definition

$n! = n \cdot (n-1) \cdot (n-2) \cdot \dots \cdot 2 \cdot 1$ -or- $n! = 1 \cdot 2 \cdot 3 \cdot 4 \cdot \dots \cdot (n-2) \cdot (n-1) \cdot n$ is called n **factorial**.

Example 4

Evaluate $6!$

Solution

$6! = 6 \times 5 \times 4 \times 3 \times 2 \times 1 = 720$ or $6! = 1 \times 2 \times 3 \times 4 \times 5 \times 6 = 720$

Example 5

Find the total number of ordered arrangements of the three different letters x , y , and z .

Solution

You may want to ask yourself, how many ordered arrangements begin with x ? How many begin with y and z ? You should obtain the following six different ordered arrangements.

$$\begin{array}{ccc} xyz & yxz & zxy \\ xzy & yzx & zyx \end{array}$$

There are no other possible ordered arrangements other than those listed above.

Note that for the first position we could have chosen any of the three letters. For the second position we have only two letters to choose from and the single remaining letter is placed in the third position. Therefore there are $3! = 3 \times 2 \times 1 = 6$ possible ordered arrangements or *permutations*.

Definition

A **permutation** is an ordered arrangement of n objects.

The following are examples using three different types of permutations.

Definition**Type I Permutation**

The number of permutations that can be made from n distinguishable objects is equal to $n!$

Example 6

How many different batting orders are possible for a little league baseball team that consists of 9 players?

Solution

There are $9! = 9 \times 8 \times 7 \times 6 \times 5 \times 4 \times 3 \times 2 \times 1 = 362,880$ different batting orders that can be formed.

Example 7

How many different ways can you arrange the letters in the word BRIDGE? (Note that all the letters in the word BRIDGE are different.)

Solution

There are $6! = 6 \times 5 \times 4 \times 3 \times 2 \times 1 = 720$ different letter arrangements.

Next we wish to determine how many different ordered arrangements of r objects can be formed from n objects.

Definition**Type II Permutation**

The number of ordered arrangements of r objects taken from n objects (called a permutation of r objects taken n at a time) is equal to ${}_n P_r = \frac{n!}{(n-r)!}$.

Example 8

Suppose you have 13 different colored Easter eggs and there is only enough room to display five of them on your shelf. How many different ways can this be done?

Solution

There are ${}_{13}P_5 = \frac{13!}{(13-5)!} = \frac{13!}{8!} = 154,440$ different ways you can display five of the Easter eggs on your shelf.

Example 9

How many ways can you select a president, vice-president and a secretary from a group of 11 people?

Solution

There are ${}_{11}P_3 = \frac{11!}{(11-3)!} = \frac{11!}{8!} = 990$ different ways you can select a president, vice-president and a secretary.

It should be noted that the two types of permutations above deal with n distinguishable objects. The next type of permutation deals with the case in which some of the objects are alike.

Definition**Type III Permutation**

The number of ordered arrangements (permutations) in which r_1, r_2, r_3, \dots are alike is equal to $\frac{n!}{(r_1!)(r_2!)(r_3!) \dots}$.

Example 10

How many different ordered arrangements or permutations can be made using all the letters in the word Mississippi?

Solution

There is one m, 4 i's, 4 s's and 2 p's. Therefore there are $\frac{11!}{(1!)(4!)(4!)(2!)} = 34,650$ different permutations that can be made from Mississippi.

Example 11

How many different permutations of the letters in the word statistics are there?

Solution

There are $\frac{10!}{(3!)(3!)(1!)(2!)(1!)} = 50,400$ different permutations that can be made.

Suppose we wish to determine how many different groups of r objects can be formed from n objects where we are not concerned with any order arrangement within the group of r objects. These types of problems, where order does not matter, are called combination problems.

Definition

A **combination** is a non-ordered arrangement of n objects taken r at a time. The number of different groups of size r that can be formed from n objects is calculated by the formula ${}_n C_r = \frac{n!}{r!(n-r)!}$.

Example 12

How many committees of 4 people can be formed from a group of 20 people?

Solution

${}_{20} C_4 = \frac{20!}{(4!)(20-4)!} = \frac{20!}{(4!)(16!)} = 4,845$ possible committees

Example 13

How many different groups of three boys and two girls can be formed from a class of nine boys and seven girls.

Solution

First we calculate the number of groups of three boys chosen out of nine:

$${}_9 C_3 = \frac{9!}{(3!)(9-3)!} = \frac{9!}{(3!)(6!)} = 84 \text{ possible groups of three boys}$$

Now we calculate the number of groups of two girls chosen out of seven.

$${}_7 C_2 = \frac{7!}{(2!)(7-2)!} = \frac{7!}{(2!)(5!)} = 21 \text{ possible groups of two girls}$$

The *multiplication principle* tells us that the number of possible combinations of these two groups is $84 \times 21 = 1,764$. So there are 1,764 possible groups of three boys.

Example 14

How many poker hands consisting of two aces and three kings are possible?

Solution

First we calculate the number of ways to choose two aces out of the four in a poker deck.

$${}_4C_2 = \frac{4!}{(2!)(4-2)!} = \frac{4!}{(2!)(2!)} = 6 \text{ ways to pick two aces}$$

Now we calculate the number of ways to choose three aces out of the four in a deck.

$${}_4C_3 = \frac{4!}{(3!)(4-3)!} = \frac{4!}{(3!)(1!)} = 4 \text{ ways to pick three kings}$$

The *multiplication principle* tells us that the number of possible combinations of these two groups is $6 \times 8 = 48$. So there are 48 possible poker hands consisting of two aces and three kings.

Solve each problem.

1. A deli offers a choice of three types of bread, four kinds of cheese and four different meats for sandwiches. How many different sandwiches is it possible to order?
2. In a three digit number, the hundreds digit can be 2, 4, 6 or 8, the tens digit can be 3, 5 or 7, and the ones digit can be 1, 3, or 9. How many numbers fit this description?
3. John has 5 shirts and 4 pairs of pants. How many different outfits can he make from this selection?
4. There are four roads from Pointville to Lineton and three roads from Lineton to Planeville. How many routes are there from Pointville to Planeville passing through Lineton?

Evaluate each factorial expression.

- | | | | |
|--------------------|-----------------------|-----------------------------|----------------------------|
| 5. $3!$ | 6. $4!$ | 7. $5!$ | 8. $8!$ |
| 9. $\frac{8!}{7!}$ | 10. $\frac{12!}{11!}$ | 11. $\frac{10,000!}{9998!}$ | 12. $\frac{10!}{(4!)(6!)}$ |

Evaluate where ${}_n P_r = \frac{n!}{(n-r)!}$ and ${}_n C_r = \frac{n!}{r!(n-r)!}$.

- | | | | |
|----------------------|---------------------|----------------------|---------------------|
| 13. ${}_5 P_2$ | 14. ${}_5 P_5$ | 15. ${}_5 C_2$ | 16. ${}_5 C_5$ |
| 17. ${}_{14} P_{13}$ | 18. ${}_{5000} P_1$ | 19. ${}_{14} C_{13}$ | 20. ${}_{5000} C_1$ |

How many different ways can the letters of these words be rearranged?

- | | | |
|-----------|-------------|----------------|
| 21. CAT | 22. DUCK | 23. MOUSE |
| 24. MOOSE | 25. CHEESES | 26. BOOKKEEPER |

Solve each problem.

27. How many ways can four people be chosen from a group of fifteen?
28. How many ways can five cards be chosen from a deck of fifty-two?
29. How many ways can a president, vice-president, and treasurer be elected from a class of thirty students?
30. Question for thought: Is the combination for a combination lock a permutation or a combination? Why?

- | | | | |
|---------------------------|-------------------|-----------------------|------------------|
| 1. 48 | 2. 36 | 3. 20 | 4. 12 |
| 5. 6 | 6. 24 | 7. 120 | 8. 40,320 |
| 9. 8 | 10. 12 | 11. 99,990,000 | 12. 210 |
| 13. 20 | 14. 120 | 15. 10 | 16. 1 |
| 17. 87,178,291,200 | | 18. 5000 | 19. 14 |
| 20. 5000 | 21. 6 | 22. 24 | 23. 120 |
| 24. 60 | 25. 420 | 26. 151,200 | 27. 1365 |
| 28. 2,598,960 | 29. 24,360 | | |
- 30.** The numbers of a “combination” lock must be entered in a specific order so it might be more appropriate to call it a “permutation” lock.

§7-2**PROBABILITY****Definition**

Suppose an experiment has n possible outcomes and each outcome is equally likely to occur. If some event A were satisfied by m of those n , then **the probability that event A occurs** is $\frac{m}{n}$. This is written as $P(A) = \frac{m}{n}$.

Example 1

Suppose a small urn contains seven marbles, three of which are red and four of which are yellow. Suppose a single marble is drawn at random from the bag. What is the probability that a red marble is drawn?

Solution

There are 7 possible outcomes since there are seven marbles to choose from. Choosing any one of the red marbles will indicate a success. Since there are three red marbles in the urn, the probability that a red marble is drawn equals $\frac{3}{7}$.

$$P(\text{red marble is drawn}) = \frac{3}{7}.$$

Example 2

Suppose a fair, six-sided die is rolled. What is the probability that you roll a three?

Solution

There are six possible outcomes: $\{1, 2, 3, 4, 5, 6\}$, all of which are equally likely to occur. Rolling a 3 will indicate a success. Since there is only one way to roll a 3, the probability of rolling a three is $\frac{1}{6}$. $P(\text{red marble is drawn}) = \frac{1}{6}$.

Definition

Two events A and B are said to be **independent** of one another if the occurrence of event A does not effect the probability that event B occurs and vice-versa. In the case where the events are defined to be independent, the probability that both event A and event B occur, $P(AB)$, is the product of $P(A)$ and $P(B)$.

$$P(AB) = P(A) \cdot P(B)$$

Example 3

Using the urn in *Example 1* we will draw one marble, note its color, return it to the urn, shake up the urn and draw another marble. What is the probability that we will select two red marbles?

Solution

Let event A be the selection of a red marble on the first draw. Let event B be the selection of a red marble on the second draw. Since the marble was been replaced in the urn after the first draw, the total number of possible outcomes for the second draw was unchanged. In this case the two events are classified as independent events.

From *Example 1* we know that:

$$P(\text{red marble is drawn}) = \frac{3}{7} \text{ and so } P(A) = \frac{3}{7} \text{ and } P(B) = \frac{3}{7}.$$

$$\text{Therefore } P(AB) = P(A) \cdot P(B) = \frac{3}{7} \cdot \frac{3}{7} = \frac{9}{49}.$$

Definition

If the events A and B are not independent they are said to be **dependent** events.

Example 4

If we have already drawn a red marble from the urn in *Example 1* and we draw another marble without replacing the first, what is the probability that the second marble is also red?

Solution

If we have drawn a red marble then there are 2 red marbles and 4 white marbles left.

Therefore the probability of drawing a second red marble is

$$P(\text{drawing a second red marble}) = \frac{2}{6} = \frac{1}{3}.$$

Since the first marble was not replaced, the chances of choosing a red ball on the second draw is not the same as it was in the *Example 3*. Therefore the two events are said to be dependent.

Example 5

Suppose a fair coin is tossed in the air three separate times. On the first toss the coin lands tails. On the second toss the coin lands heads. What is the probability that on the third toss the coin lands tails?

Solution

On the third toss the number of possible outcomes is two, either heads or tails. It does not matter how the coin landed on the previous two tosses, these previous events have no affect on the outcome of the third toss. Therefore the probability of the coin landing tails on the third toss is:

$$P(\text{tails on third toss}) = \frac{1}{2}.$$

Example 6

Suppose we have drawn two kings from a regular deck of playing cards and not replaced them. What is the probability of drawing a third king on our next draw?

Solution

There were originally four kings out of fifty-two cards. Now there are only two kings left out of fifty cards. Thus

$$P(\text{king on third draw}) = \frac{2}{50} = \frac{1}{25}.$$

Example 7

Suppose that the integers from 2 through 15 inclusive are written on slips of paper which are to be randomly drawn from a hat. A 4 is randomly selected on the first draw and not replaced. What is the probability that an odd number is randomly selected on the second draw?

Solution

Before the first number is drawn there are 7 odd numbers out of 14 numbers total:

$$\{ 3, 5, 7, 9, 11, 13, 15 \}$$

After the 4 is drawn, there are still 7 odd numbers, but now there are 13 numbers total. Thus

$$P(\text{odd number on second draw}) = \frac{7}{13}.$$

One card is selected at random from a regular deck of 52 cards.

Find the probability of drawing each card described below.

1. A club
2. An ace
3. The ace of clubs
4. An ace or a club
5. An ace or a queen
6. Not the ace of clubs

A fair coin is flipped three times in row. Find the probability of each event below.

7. All three tosses come up heads.
8. At least two tosses come up heads.
9. At least one toss comes up heads.
10. Exactly one toss comes up heads.

A number, n , between 1 and 30 (inclusive) is selected at random.

Find each probability below.

11. $P(n \text{ is even})$
12. $P(n \leq 4)$
13. $P(n > 10)$
14. $P(n \text{ is divisible by } 3)$
15. $P(n \text{ is odd and has only one digit})$

A card is drawn from a 52 card bridge deck, replaced, the deck shuffled, and a second card is drawn. Find the probability of each event below.

16. Both cards are sevens.
17. Both cards are red.
18. Neither card is a heart.
19. Both cards are hearts.
20. The first card is a heart and the second card is a club.

Find the probability of each event below.

21. What is the probability that two cards drawn randomly without replacement from a regular deck of cards will both be kings?
22. Three dice are rolled. What is the probability that each produces a 1 or a 2?
23. A jar contains 3 blue marbles, 4 red marbles and 2 white marbles. A blue marble is selected at random and not replaced. What is the probability that the next randomly selected marble is also blue?
24. Two dice are tossed. What is the probability that their product is 12?
25. A lottery selects six numbers without replacement from a the numbers 1 through 50. What is the probability that you will win the lottery with a single ticket?

- | | | | | | | | | | |
|-----|-----------------|-----|----------------|-----|----------------|-----|----------------|-----|------------------------|
| 1. | $\frac{1}{4}$ | 2. | $\frac{1}{13}$ | 3. | $\frac{1}{52}$ | 4. | $\frac{4}{13}$ | 5. | $\frac{2}{13}$ |
| 6. | $\frac{51}{52}$ | 7. | $\frac{1}{8}$ | 8. | $\frac{1}{2}$ | 9. | $\frac{7}{8}$ | 10. | $\frac{3}{8}$ |
| 11. | $\frac{1}{2}$ | 12. | $\frac{2}{15}$ | 13. | $\frac{2}{3}$ | 14. | $\frac{1}{3}$ | 15. | $\frac{1}{6}$ |
| 16. | $\frac{1}{169}$ | 17. | $\frac{1}{4}$ | 18. | $\frac{9}{16}$ | 19. | $\frac{1}{16}$ | 20. | $\frac{1}{16}$ |
| 21. | $\frac{1}{221}$ | 22. | $\frac{1}{27}$ | 23. | $\frac{1}{4}$ | 24. | $\frac{1}{9}$ | 25. | $\frac{1}{15,890,700}$ |

§7-3**TABLES AND GRAPHS**

Suppose a researcher collects data on the number of unemployed people in a major metropolitan city during the years 1981, 1982, 1983, 1984, 1985, 1986, and 1987. The data in its original form is summarized in the table below.

<u>Year</u>	<u>Average Number of Unemployed People</u>
1981	2,000
1982	4,000
1983	9,000
1984	18,000
1985	8,000
1986	6,000
1987	3,000

It is easier for most people to comprehend the meaning of data when it is presented graphically. For example, the data in the table above shows an increase in the average number of people unemployed through the years 1981 to 1984. Then the data shows a decrease in the number of people that are unemployed through the years 1984 to 1987.

The bar graph below was constructed to represent the data in the table above. Here it is easier to view the trend of the average number of unemployed people through the years 1981 to 1987.

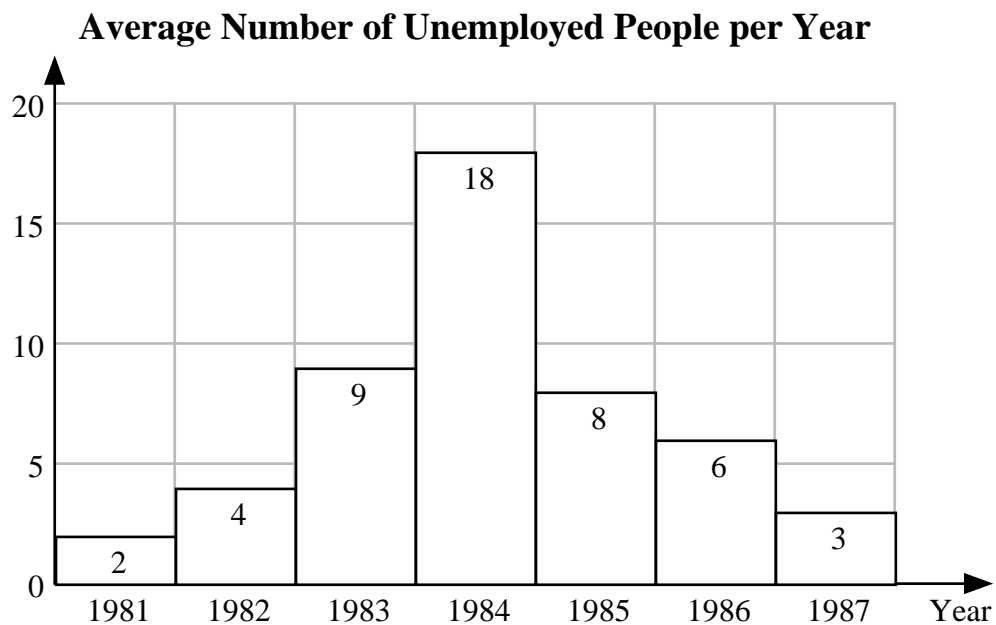

Graph 1

Notice the horizontal axis is used to represent the years and the vertical axis is used to represent the average number of unemployed people. The vertical axis is labeled with integer values that are understood to be thousand's of people. For example, in the year 1985 the bar graph indicates an integer value of 8 on the vertical axis. Therefore, in the year 1985 there was an average of 8 times 1,000 = 8,000 people unemployed in that year.

The numbers on top of each bar in the graph above are generally not shown. There were placed here to ensure that the reader understands how a bar graph is read.

Example 1 Using graph 1 above, what was the average number of unemployed people for the three-year period from 1981 to 1983?

Solution The integer values for 1981, 1982 and 1983 are 2, 4 and 9. The average of these three values is $\frac{2+4+9}{3} = \frac{15}{3} = 5$. Recalling that these integer values represent thousands of people, the average number of unemployed people for the three-year period was 5,000 people.

A line graph can also be used to represent data. Below is the line graph that represents the exact same data used in Graph 1.



Graph 2

Example 2 Using the line graph above, how many years did it take for the average number of unemployed people to increase above 17,000 people.

Solution At the end of 1983 there was an average of 9,000 people unemployed. At the end of 1984 there was an average number of 18,000 people unemployed. Therefore during the 1984 year, the average number of unemployed people increased above 17,000. Hence, it took 4 years for the average number of unemployed people to increase above 17,000 people.

Example 3 Using the line graph above, during what year did the average number of unemployed people decrease the least.

Solution After 1984 the average number of unemployed people begins to decrease. In 1985 it decreased by 10,000 people. In 1986 it decreased by 2,000 people. In 1987 it decreased by 3,000 people. Therefore during 1986, the average number of unemployed people decreased the least.

The circle graph or pie graph is used to show how something is composed of different things. For example, let's look at a candy bar whose ingredients are chocolate, peanuts and caramel. For example, suppose $\frac{3}{5}$ (60%) of the candy bar is composed of chocolate, $\frac{1}{5}$ (20%) of the candy bar is composed of peanuts and $\frac{1}{5}$ (20%) of the candy bar is composed of caramel. This numerical data is represented in the pie graphs shown below.

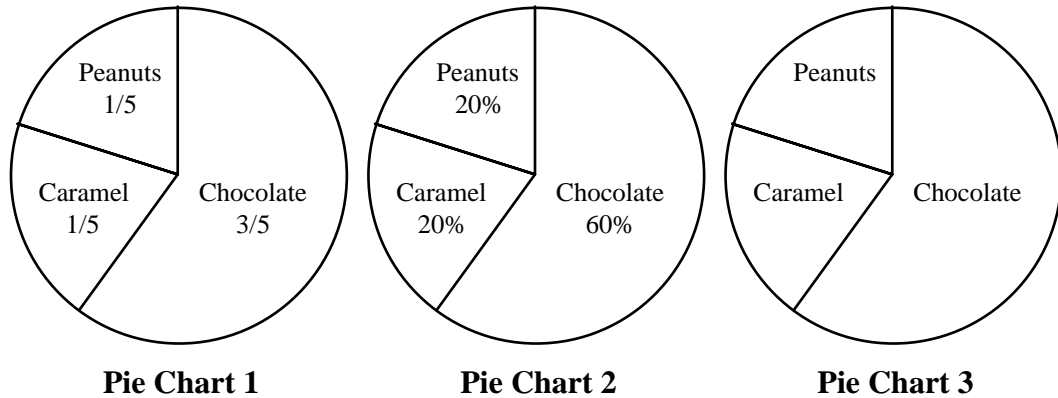

Pie chart 1 uses fractions to describe the composition of the candy bar where pie chart 2 uses percentages. Pie chart 3 requires the reader to convert the area of the three regions to a percentage or fractional value where the entire area of the circle is equivalent to 100% or 1.

Example 4 If the total weight of the candy bar was 4.0 grams, what how many grams of chocolate are in each candy bar?

Solution Since the total weight of the candy bar is 4.0 grams and 60% of it is composed of peanuts, the weight of the peanuts alone is $(4.0) \times (0.60) = 2.4$ grams.

Example 5 If the total weight of the candy bar was 6.0 grams, what how many grams of peanuts are in each candy bar?

Solution Since the total weight of the candy bar is 6.0 grams and $\frac{1}{5}$ of it is composed of peanuts, the weight of the peanuts alone is $(6.0) \times \left(\frac{1}{5}\right) = \frac{6}{5} = 1.2$ grams.

§7-4**STATISTICS****Definition**

Statistics is the science of conducting studies to collect, organize, summarize, analyze, and draw conclusions from data.

When working with large collections of data, the concept of “average” is very useful. There are many types of average, but those most commonly used are called the *mean*, the *median*, and the *mode*.

Definition

The **mean** is sometimes referred to as the *arithmetic average* of the data. It is the sum of the values of the items in the data set divided by the number of items in the data set.

$$\text{The mean} = \frac{a_1 + a_2 + \dots + a_n}{n} \text{ where } a_1, a_2, \dots, a_n \text{ are the values of } n \text{ items.}$$

Example 1

Find the mean of the following data: 1, 4, 2, 6, 2.

Solution

$$\text{mean} = \frac{1 + 4 + 2 + 6 + 2}{5} = \frac{15}{5} = 3$$

Definition

The **median** is the middle value when the data is ordered from smallest value to largest value. If there are an even number of values then the median is the average of the two middle values.

Example 2

Find the median of the following data: 1, 4, 2, 6, 2.

Solution

Ordering the data from smallest value to largest value gives us 1 2 2 4 6.
The middle number is the second 2 so 2 is the median.

Definition

The **mode** is the value that most frequently occurs in the data set. It is possible to have no mode or more than one mode. A set of data with two modes is called a **bimodal** distribution.

Example 3

Find the mode of the following data: 1, 4, 2, 6, 2.

Solution

Since the number 2 appears twice and each other number appears only once, 2 is the mode.

Example 4 A class earns the following scores on a pop-quiz: 0, 52, 52, 60, 72, 82, 85, 85, 99, 100. Find the mean the median and mode(s) for these class scores.

Solution The mean
The scores add up to 687. Since there are 10 scores the mean is given by:

$$\text{mean} = \frac{687}{10} = 68.7$$

The median
Ordering the scores from smallest to largest gives us:

0 52 52 60 72 82 85 85 99 100

Since there are an even number of scores, there are two middle numbers: 72 and 82.
The median is the average of these two numbers: $\frac{72 + 82}{2} = 77$

The mode
The most frequently occurring scores are 52 and 85, both of which occur twice. Thus 52 and 85 are both modes.

Example 5 A bakery sells donuts individually, in packages of 6 and in packages of 12. The sales for one day are shown below. If there were 50 customers, then what is the average number of donuts purchased by each customer?

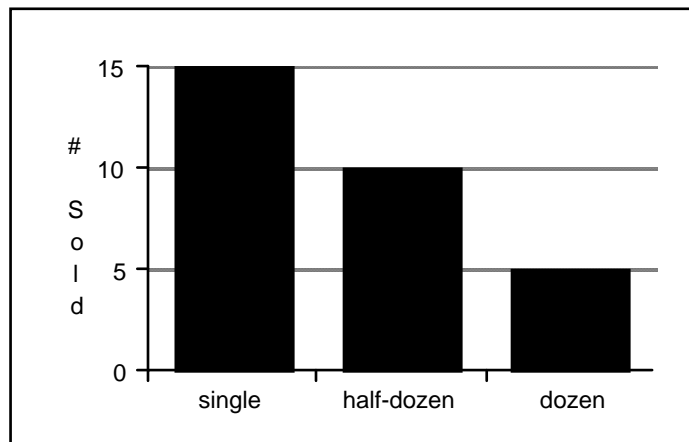

Solution There were 15 individual donuts sold: $15 \cdot 1 = 15$
There were 10 packages of a half-dozen sold: $10 \cdot 6 = 60$
There were 5 packages of a dozen sold: $5 \cdot 12 = 60$

Thus a total of 135 donuts were sold to 50 customers so the mean is $\frac{135}{50} = 2.7$.

§7-4**PROBLEM SET**

Find the Mean, Median and Mode(s) of each set of data.

1. { 4, 7, 2, 4, 3 }
2. { 7, 1, 3, 9, 5, 6, 3, 7 }
3. { -2.5, 1.25, -4, 2.75, 3.5 }
4. { 6, 9, 2, 5, 14, 6, 8 }
5. { 38, 42, 35, 17, 24, 38, 21 }
6. { 5, 12, 15, 5, 9, 12, 17, 5 }
7. { 42, 60, 36, 52, 48, 36, 42 }
8. { 127, 108, 120, 116, 127, 118 }
9. { 96, 94, 88, 89, 88 }
10. { 70, 70, 90, 100, 75, 60, 95 }
11. { 14.0, 13.4, 13.2, 14.0, 13.9 }
12. { 1.4, 32.4, 64.4, 18, 32.4, 25, 10 }
13. { 10.5, 30.6, 98.6, 101, 48.8, 46.8 }
14. { 126, 147, 140, 126, 136, 131, 118 }
15. { 32, 28, 19, 24, 28, 19, 26, 27, 30, 28, 25 }
16. { 38, 40, 20, 21, 30, 33, 24, 20, 37, 40 }
17. { 20, 14, 52, 40, 39, 18, 14, 15, 0, 38 }
18. { 11,500; 101,000; 51,000; 75,000; 8,500 }
19. { 9.16, 8.44, 7.60, 4.35, 0.97, 4.35, 8.44 }
20. The following histogram represents the quiz scores for a group of students. Find the mean, median and mode of the set of data.

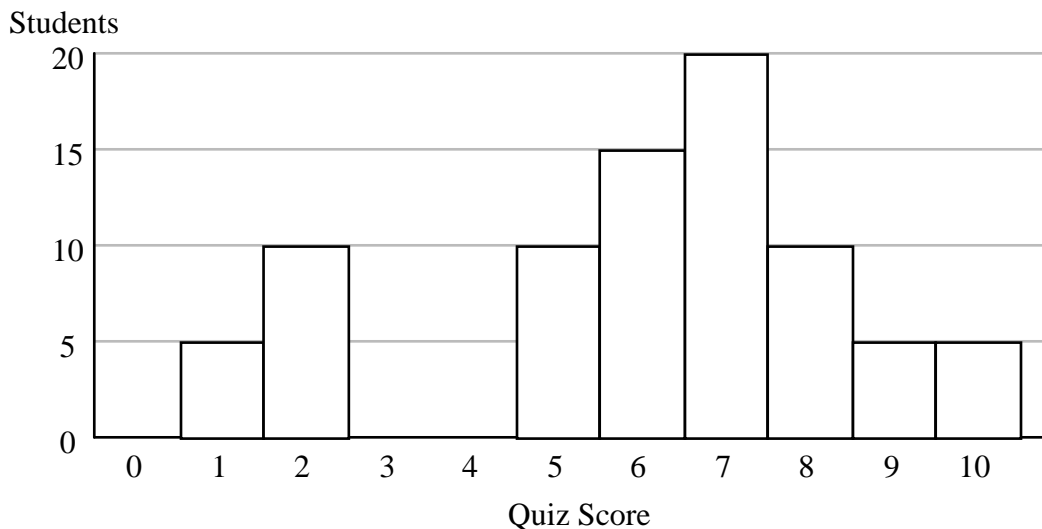

1. mean = 4; median = 4; mode = 4
2. mean = 5.125; median = 5.5; mode = 7 and 3
3. mean = 0.2; median = 1.25; mode = none
4. mean \approx 7.14; median = 6; mode = 6
5. mean \approx 30.71; median = 35; mode = 38
6. mean = 10; median = 10.5; mode = 5
7. mean \approx 45.14; median = 42; mode = 42 and 36
8. mean \approx 119.3; median = 119; mode = 127
9. mean = 91; median = 89; mode = 88
10. mean = 80; median = 75; mode = 70
11. mean = 13.7; median = 13.9; mode = 14.0
12. mean \approx 26.23; median = 25; mode = 32.4
13. mean = 56.05; median = 47.8; mode = none
14. mean = 132; median = 131; mode = 126
15. mean = 26; median = 27; mode = 28
16. mean = 30.3; median = 31.5; mode = 40 and 20
17. mean = 25; median = 19; mode = 14
18. mean = 49,400; median = 51,000; mode = none
19. mean \approx 6.19; median = 7.60; mode = 8.44 and 4.35
20. mean = 6; median = 6.5; mode = 7